



**INSTRUMENTS**

# **Beacon 410A Gas Monitor**

## **Operator's Manual**

*Part Number: 71-0397*

*Revision: K*

*Released: 9/26/22*

**RKI Instruments, Inc.**  
**[www.rkiinstruments.com](http://www.rkiinstruments.com)**

# Product Warranty

RKI Instruments, Inc., warrants gas alarm equipment sold by us to be free from defects in materials, workmanship, and performance for a period of one year from date of shipment from RKI Instruments, Inc. Any parts found defective within that period will be repaired or replaced, at our option, free of charge. This warranty does not apply to those items, which by their nature, are subject to deterioration or consumption in normal service, and which must be cleaned, repaired, or replaced on a routine basis. Examples of such items are as follows:

- Absorbent cartridges
- Fuses
- Pump diaphragms and valves
- Batteries
- Filter elements

Warranty is voided by abuse including mechanical damage, alteration, rough handling, or repair procedures not in accordance with the operator's manual. This warranty indicates the full extent of our liability, and we are not responsible for removal or replacement costs, local repair costs, transportation costs, or contingent expenses incurred without our prior approval.

THIS WARRANTY IS EXPRESSLY IN LIEU OF ANY AND ALL OTHER WARRANTIES AND REPRESENTATIONS, EXPRESSED OR IMPLIED, AND ALL OTHER OBLIGATIONS OR LIABILITIES ON THE PART OF RKI INSTRUMENTS, INC., INCLUDING BUT NOT LIMITED TO, THE WARRANTY OF MERCHANTABILITY OR FITNESS FOR A PARTICULAR PURPOSE. IN NO EVENT SHALL RKI INSTRUMENTS, INC., BE LIABLE FOR INDIRECT, INCIDENTAL, OR CONSEQUENTIAL LOSS OR DAMAGE OF ANY KIND CONNECTED WITH THE USE OF ITS PRODUCTS OR FAILURE OF ITS PRODUCTS TO FUNCTION OR OPERATE PROPERLY.

This warranty covers instruments and parts sold to users by authorized distributors, dealers, and representatives as appointed by RKI Instruments, Inc.

We do not assume indemnification for any accident or damage caused by the operation of this gas monitor, and our warranty is limited to the replacement of parts or our complete goods.

# Table of Contents

<b>Chapter 1: Introduction</b> .....	<b>5</b>
Overview .....	5
About the Beacon 410A Gas Monitor .....	5
About this Manual .....	5
Specifications .....	6
<b>Chapter 2: Description</b> .....	<b>8</b>
Overview .....	8
External Description .....	8
Internal Description .....	10
Optional Accessories .....	18
<b>Chapter 3: Installation and Start Up</b> .....	<b>22</b>
Overview .....	22
Mounting the Beacon 410A Gas Monitor .....	22
Wiring the Beacon 410A Gas Monitor .....	24
Starting Up the Beacon 410A Gas Monitor .....	35
<b>Chapter 4: Operation</b> .....	<b>37</b>
Overview .....	37
Normal Operation .....	37
4 - 20 mA Signal Output Operation .....	38
Viewing and Resetting Min/Max Readings .....	39
Battery Charging (Optional) .....	39
Alarm Indications .....	40
<b>Chapter 5: Global Menu</b> .....	<b>47</b>
Overview .....	47
Viewing and Changing Global Parameters .....	47
<b>Chapter 6: Configuration Menu</b> .....	<b>50</b>
Overview .....	50
Viewing and Changing Channel Parameters .....	50

<b>Chapter 7: Input Setup Menu</b> .....	<b>57</b>
Overview .....	57
Selecting the Detector Head Input Type and Gas Setup .....	57
<b>Chapter 8: Calibration Mode</b> .....	<b>61</b>
Overview .....	61
Calibration Frequency .....	62
Detector Head Types .....	62
Calibration Gas Response Memory Feature .....	63
Entering Calibration Mode .....	63
Calibration Timeout Setting .....	64
Performing a Calibration .....	65
Viewing Maximum Spans .....	70
<b>Chapter 9: RS-485 Modbus Output</b> .....	<b>71</b>
Overview .....	71
Wiring the Beacon 410A in a Modbus System .....	71
Using the Beacon 410A in a 4-wire Modbus System .....	74
Modbus Menu .....	74
Supported Modbus Functions .....	76
<b>Chapter 10: Maintenance</b> .....	<b>81</b>
Overview .....	81
Preventive Maintenance .....	81
Troubleshooting .....	81
Replacing the Fuses .....	83
<b>Chapter 11: Parts List</b> .....	<b>84</b>

# Chapter 1: Introduction

---

## Overview

This chapter briefly describes the Beacon 410A Gas Monitor. This chapter also describes the *Beacon 410A Gas Monitor Operator's Manual* (this document). Table 1 at the end of this chapter lists the specifications for the Beacon 410A.

---

## About the Beacon 410A Gas Monitor

The Beacon 410A is a fixed-mounted, continuous-monitoring controller. This multiple channel gas monitor is capable of detecting gas at up to four locations. The display screen simultaneously displays the gas readings of all active channels. Both direct connect (internal amplifier type) detector heads and 4 - 20 mA transmitter (remote amplifier type) detector heads may be used with the Beacon 410A.

The Beacon 410A includes audible and visual alarms that warn you of hazardous gas conditions. The alarm circuits include up to three levels of gas alarms. The fail circuit alerts you to failures in the detector heads or Beacon 410A.

The Beacon 410A has four selection menus that allow you to configure various Beacon 410A channel and instrument parameters, the Global Menu, Configuration Menu, Input Setup Menu, and Modbus Menu. It also has an operational mode, Calibration Mode, that enables you to calibrate the Beacon 410A's active channels.

---

## About this Manual

The *Beacon 410A Gas Monitor Operator's Manual* is organized as follows:

- **Chapter 1** is an introduction to the Beacon 410A.
- **Chapter 2** describes the components of the Beacon 410A.
- **Chapter 3** describes the installation and start-up procedures of the Beacon 410A.
- **Chapter 4** describes the operation of the Beacon 410A.
- **Chapter 5** describes the Global Menu which allows you to set instrument parameters.
- **Chapter 6** describes the Configuration Menu which allows you to set channel parameters.
- **Chapter 7** describes the Input Setup Menu which allows you to set the input type for each channel.
- **Chapter 8** describes Calibration Mode which allows you to calibrate the Beacon 410A's active channels.
- **Chapter 9** describes the Beacon 410A's RS-485 Modbus output.
- **Chapter 10** describes the Beacon 410A's maintenance requirements and procedures.

The *Beacon 410A Gas Monitor Operator's Manual* uses the following conventions for notes, cautions, and warnings:

---

**NOTE:** Describes additional or critical information.

---



---

**CAUTION:** Describes potential damage to equipment.

---



---

**WARNING:** Describes potential danger that can result in injury or death.

---



Caution: refer to accompanying documentation

~ Vac (AC voltage)

— Vdc (DC voltage)

---



## Specifications

Table 1 lists specifications for the Beacon 410A.

**Table 1: Beacon 410A Specifications**

<b>Input Power</b>	100/115/220V ~ ±10%, 50/60Hz, 1.0/1.0/0.5A <b>or</b> 24 V — ± 10%, 2.5A
<b>Construction (housing)</b>	Fiberglass/polyester with lexan window (NEMA 4X)
<b>Dimensions</b>	12.5 in. H x 11.0 in. W x 6.4 in. D (31.8 cm H x 27.9 cm W x 16.3 cm D)
<b>Weight</b>	10.4 lbs. (without AC line cord)
<b>Environmental Conditions</b>	<ul style="list-style-type: none"> <li>• For indoor or outdoor locations (Type 4X)</li> <li>• 2000m max. altitude</li> <li>• -40°C to 50°C (-4°F to 122°F) max. ambient</li> <li>• Maximum humidity of 80% relative</li> <li>• Mains supply voltage fluctuations not exceeding ± 10% of nominal</li> <li>• DC supply voltage fluctuations not exceeding +10% -8% of nominal</li> <li>• Overvoltage Category II, Pollution Degree 2</li> </ul>

**Table 1: Beacon 410A Specifications**

<b>Safety/Regulatory</b>	C  US 186718
<b>User Controls</b>	<ul style="list-style-type: none"><li>• Reset switch</li><li>• Program buttons: ESCAPE, UP/YES, DOWN /NO, and ENTER)</li></ul>
<b>Relays</b>	<ul style="list-style-type: none"><li>• Relay contacts rated for 10A @ 115/220V~ resistive or 10A @ 30V  resistive</li><li>• SPDT, Form C (common, normally open, and normally closed contacts)</li></ul>
<b>Available Power at Strobe Terminals</b>	24 VDC, 500 mA MAX
<b>Standard Accessory</b>	Operator's manual (this document)

# Chapter 2: Description

## Overview

This chapter describes the Beacon 410A's external and internal components.

## External Description

This section describes the housing and all external components of the Beacon 410A. For the purposes of this description, the housing door is considered the front of the monitor.

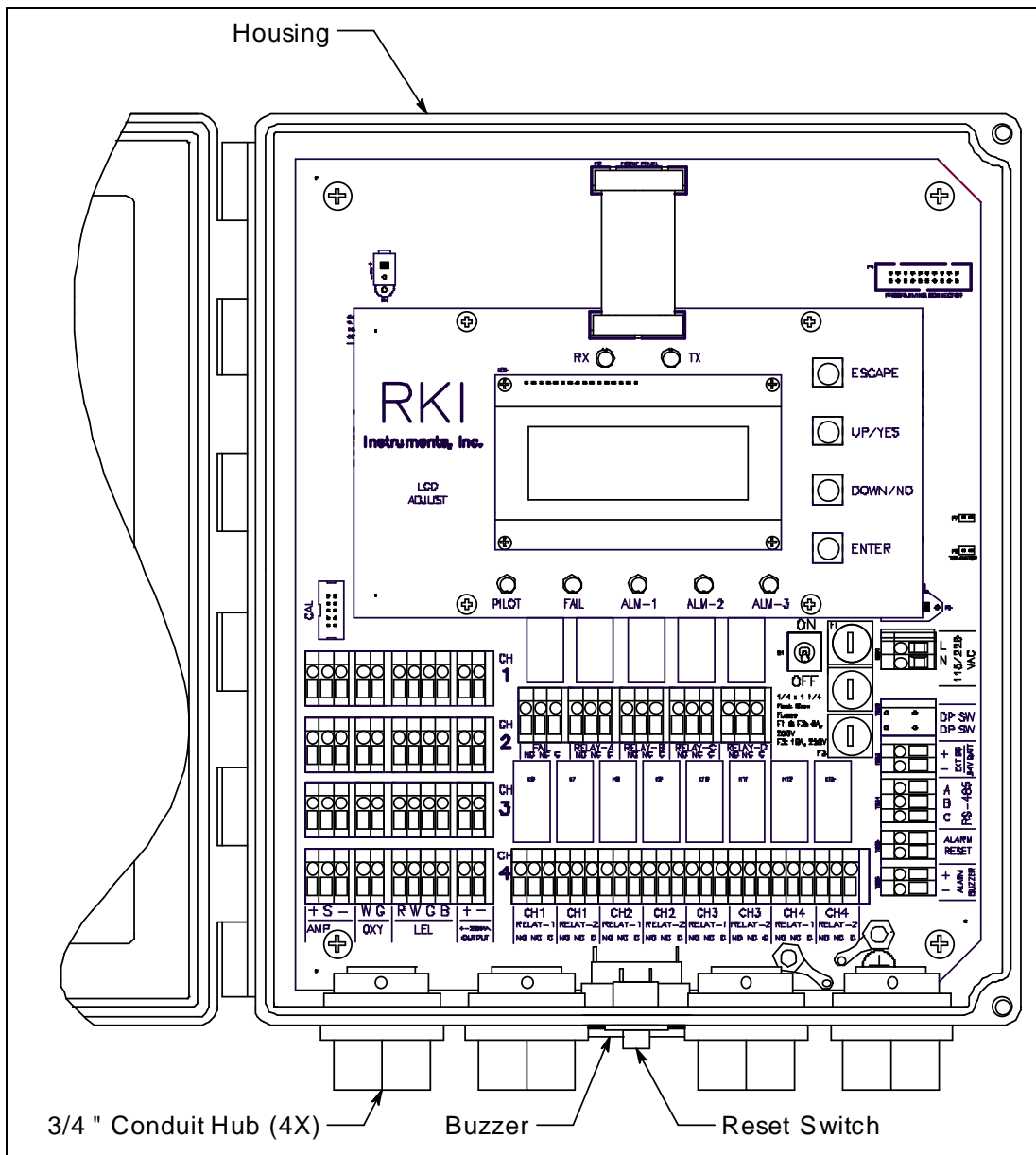

Figure 1: External Component Location



## Housing

The Beacon 410A's fiberglass housing is weather- and corrosion-resistant. It is suitable for installation where general purpose equipment is in use. The housing door is hinged on the left side and is secured by two latches on the right side. The OLED display and status LEDs are visible through windows in the housing door. Four mounting feet are attached to the back of the housing (one at each corner). The mounting feet allow you to install the housing to a vertical surface. Four conduit hubs on the bottom of the housing are for external wiring connections.

---

**CAUTION:** *Only use the four factory installed conduit hubs on the bottom of the housing for wire entry into the housing. Do not drill the housing for any reason.*

---

---

**CAUTION:** *To avoid electrical interference, do not route detector head and power wiring through the same conduit hub.*

---

## Reset Switch

The reset switch is on the bottom of the housing in front of the buzzer. The reset switch serves five functions:

- Resets the alarm circuits for “latched” alarms after an alarm 1, alarm 2, or alarm 3 condition passes.  
You can set each channel for latched or self-resetting alarms in the Configuration Menu. See “Viewing and Changing Channel Parameters” on page 50 for more information.
- Silences the buzzer during an alarm 1, alarm 2, or alarm 3 condition if the buzzer silence parameter in the Global Menu is set to **CAN SILENCE BUZZER**. See “Viewing and Changing Global Parameters” on page 47 for more information on setting the silence feature.
- Resets the strobe during an alarm 1, alarm 2, or alarm 3 condition if the strobe alarm setting parameters are set to **Resettable STROBE** in the Configuration Menu. See “Viewing and Changing Channel Parameters” on page 50 for more information on setting the strobe alarm setting parameters.
- Displays and resets the minimum and maximum gas concentration values detected.
- Silences the buzzer during a fail condition.

---

**NOTE:** Fail alarms cannot be reset with the reset switch. When a fail condition passes, the Beacon 410A will automatically reset the fail alarm circuit.

---

## Buzzer

The buzzer is on the bottom of the housing, behind the reset switch. The buzzer sounds an audible alarm to warn you of gas alarms and instrument failures.

# Internal Description

This section describes the internal components of the Beacon 410A.

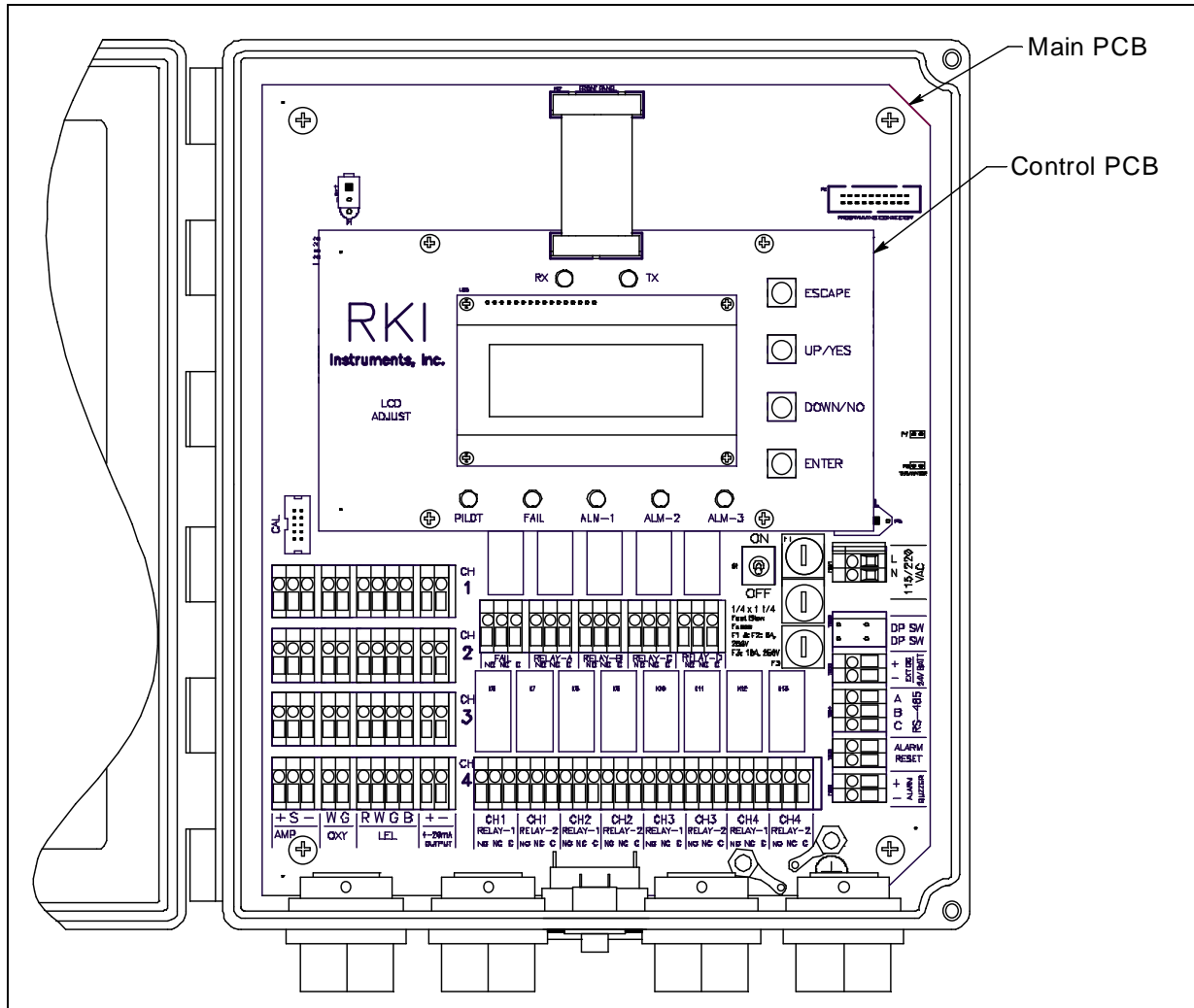
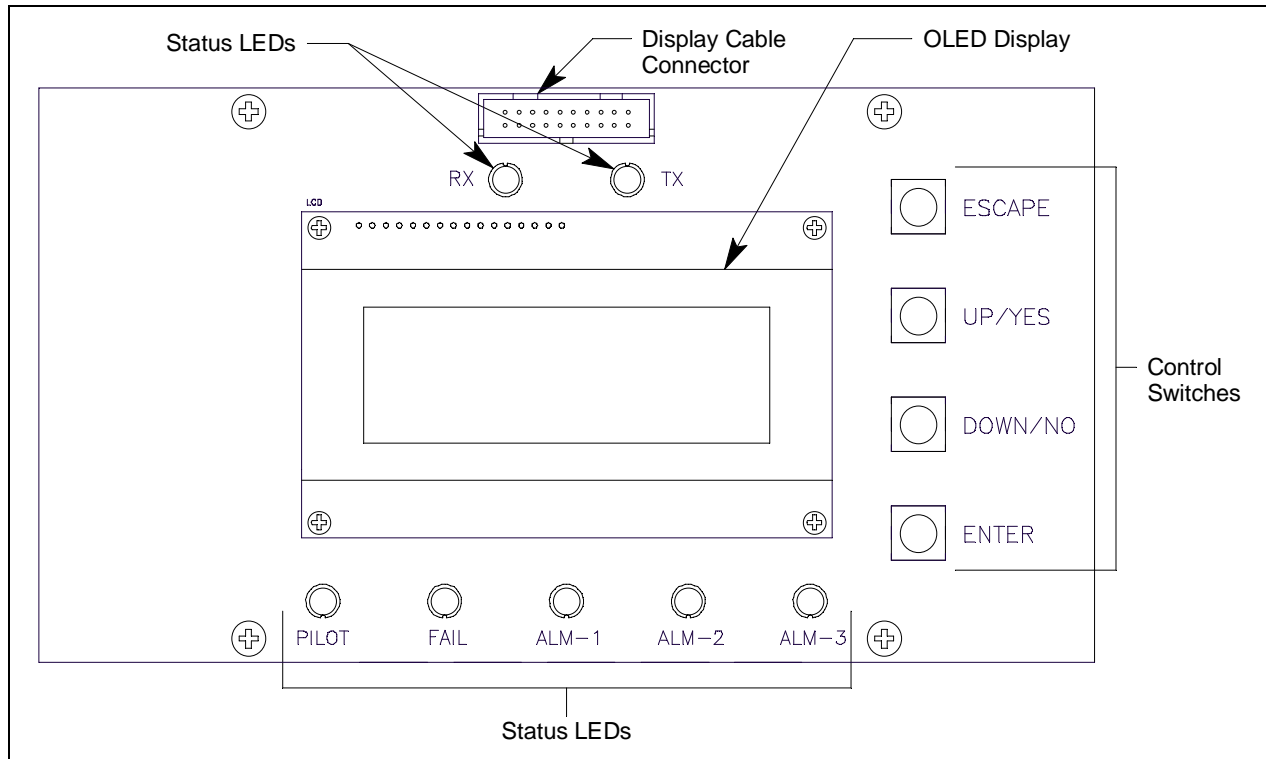

Figure 2: Beacon 410A Gas Monitor Internal Component Location

## Control PCB

The control PCB (printed circuit board) is mounted to the power supply mounting plate which is in turn mounted to the main PCB. The power supply mounting plate and main PCB are described below. The control PCB includes the OLED display, the status LEDs, and the program buttons. It is connected to the main PCB by the display cable which is a 20 conductor ribbon cable assembly. The display cable connects to a rectangular connector on the top edge of the control PCB and to the same type of connector labeled “FRONT PANEL” on the top edge of the main PCB.



**Figure 3: Control PCB Component Location**

## **OLED Display**

During normal operation, the four line display simultaneously indicates the target gas, current gas reading, and measuring unit of each active channel. The display also shows messages, settings, and other data when you are operating the various selection menus and operating modes. The display appearance cannot be adjusted so no adjustment pot is needed for the OLED display.

## **Status LEDs**

The Beacon 410A includes seven status LEDs that indicate the current status of the monitor: the RX & TX LEDs, the pilot LED, the fail LED, the alarm 1 LED, the alarm 2 LED, and the alarm 3 LED (see Figure 3).

- **RX & TX LEDs**

These LEDs indicate data being received (RX) and transmitted (TX) when the Beacon 410A's Modbus output is operating.

- **Pilot LED**

The PILOT LED is on when the Beacon 410A is receiving incoming power, either AC or DC power.

- **Fail LED**

The fail LED turns on when the Beacon 410A is experiencing a fail condition. A fail condition can be caused by a failure within the Beacon 410A or the detector heads wired to the Beacon 410A (see "Chapter 10: Maintenance" on page 81).

- **Alarm 1 LED**  
The alarm 1 LED is on when the Beacon 410A is experiencing an alarm 1 condition.
- **ALARM 2 LED**  
The alarm 2 LED is on when the Beacon 410A is experiencing an alarm 2 condition.
- **ALARM 3 LED**  
The alarm 3 LED is on when the Beacon 410A is experiencing an alarm 3 condition.

## **Control Buttons**

The Beacon 410A includes four control buttons that allow you to enter the selection menus and Calibration Mode, navigate through the menus and Calibration Mode, update instrument and channel parameter settings, and save changes to the settings. The control buttons, listed in Table 2, are to the right of the OLED display (see Figure 3).

**Table 2: Beacon 410A Control Button Functions**

<b>Button</b>	<b>Function</b>
ESCAPE	<ul style="list-style-type: none"> <li>• Moves backward through the menu and mode screens</li> <li>• Aborts operations</li> <li>• Cancels changes you make in the menus</li> <li>• Enters the Configuration Menu (press with ENTER button)</li> <li>• Enters the Global Menu (press with the UP/YES button)</li> </ul>
UP (YES)	<ul style="list-style-type: none"> <li>• Initiates an operation or proceeds to the next screen when a yes/no question is asked on a screen</li> <li>• Changes the displayed setting</li> <li>• Enters the Global Menu (press with ESCAPE) button</li> <li>• Enters the Calibration Mode (press with ENTER button)</li> </ul>
DOWN (NO)	<ul style="list-style-type: none"> <li>• Cancels an operation or sequence when a yes/no question is asked on a screen.</li> <li>• Changes the displayed setting</li> <li>• Enters the Modbus Menu (press with ENTER button)</li> </ul>
ENTER	<ul style="list-style-type: none"> <li>• Saves changes you make in the menu and mode screens</li> <li>• Accepts the displayed parameter setting</li> <li>• Enters the Configuration Menu (press with ESCAPE button)</li> <li>• Enters Calibration Mode (press with UP/YES button)</li> <li>• Enters the Modbus Menu (press with DOWN/NO button)</li> </ul>

# Main PCB

The main PCB contains: terminal strips, relays, a termination jumper, a ground jumper, ground studs, the power switch, the power supply, and fuses.

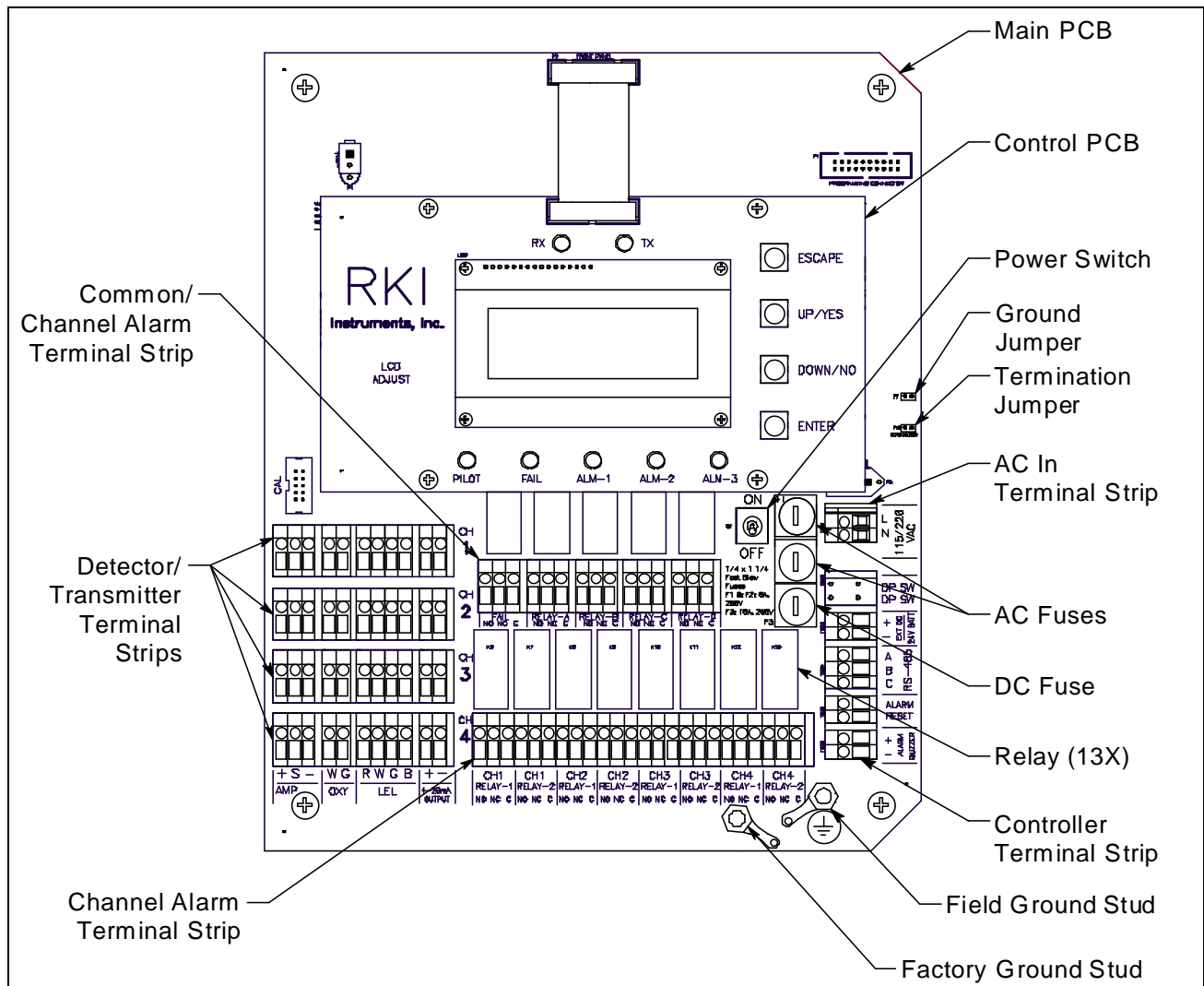

**Figure 4: Main PCB Component Location**

## Terminal Strips

The Beacon 410A includes 9 terminal strips for wiring connections. See “Wiring the Beacon 410A Gas Monitor” on page 24. for detailed wiring procedures.

- Strobe Terminal Strip

The strobe terminal strip is a 2-point terminal strip located in the upper left corner of the main PCB. When the optional strobe is ordered with a Beacon 410A, the strobe terminal strip is used to factory wire the strobe.

---

**CAUTION:** *The strobe terminals are intended for use with the RKI supplied optional strobe. Consult RKI Instruments, Inc. before attempting to use these terminals for some other alarm device.*

---

- **Detector/Transmitter Terminal Strips**  
Four detector/transmitter terminal strips are located along the bottom left side of the main PCB (see Figure 4 on page 13). These four 11-point terminal strips facilitate wiring connections to the detector heads. They also provide terminals to connect a recording device to a 4 to 20 mA output for each channel. The top terminal strip is for channel 1 connections and each subsequent strip is used for the next channel with the bottom terminal strip being for channel 4 connections.
- **Channel Alarm Terminal Strip**  
A channel alarm terminal strip is located to the right of the channel 4 detector/transmitter terminal strip (see Figure 4 on page 13). This 24-point terminal strip facilitates wiring external alarm devices (horn, light, etc.) to relay contacts that are field configurable for alarm levels and operation and are controlled by individual channels. The contacts are labeled NO (normally open), NC (normally closed), and C (common). See “Viewing and Changing Global Parameters” on page 47 and “Viewing and Changing Channel Parameters” on page 50 for instructions to configure the operation of these contacts.
- **Common/Channel Alarm Terminal Strip**  
The common/channel alarm terminal strip is located in approximately the middle of the main PCB above the channel alarm terminal strip. This 15-point terminal strip facilitates wiring external alarm devices (horn, strobe, etc.) to relay contacts that are field configurable as individual alarm contacts that are controlled by individual channels or as common alarm contacts which are controlled by all channels. The contacts are labeled NO (normally open), NC (normally closed), and C (common). See “Viewing and Changing Global Parameters” on page 47 and “Viewing and Changing Channel Parameters” on page 50 for instructions to configure the operation of these contacts.
- **Controller Terminal Strip**  
The 9-point controller terminal strip is along the lower right side of the main PCB (see Figure 4 on page 13). The controller terminal strip facilitates various internal and external wiring connections. Table 3 lists the function of each terminal.

**Table 3: Terminal Assignments for the Controller Terminal Strip**

<b>Terminal</b>	<b>Connects to:</b>
EXT DC/24V BATT +	+ connection from 24 VDC power source <sup>1</sup> (or 24 V backup battery) <sup>1</sup>
EXT DC/24V BATT -	- connection from 24 VDC power source <sup>1</sup> (or 24 V backup battery) <sup>1</sup>
RS-485 A	Allow connection of the Beacon 410A to a Modbus network
RS-485 B	
RS-485 C	
Alarm Reset	Reset Switch Terminals (factory wired)
Alarm Reset	
Alarm Buzzer +	Buzzer + connection (factory wired)

**Table 3: Terminal Assignments for the Controller Terminal Strip (Continued)**

<b>Terminal</b>	<b>Connects to:</b>
Alarm Buzzer -	Buzzer - connection (factory wired)
<i><b>NOTE:</b> If 24 VDC is used as primary power source do not make wiring connections to the AC terminal strip.</i>	

- AC Terminal Strip

The 2-point AC terminal strip is located above the controller terminal strip (see Figure 4 on page 13). The AC terminal strip facilitates wiring connections to the AC power source.

**Table 4: Terminal Assignments for the AC Terminal Strip**

<b>Terminal</b>	<b>Connects to:</b>
LINE	Hot wire from AC power source.
NEUT	Neutral wire from AC power source.

---

**NOTE:** The AC power source’s ground wire must be connected to the field ground stud. See “Detector/Transmitter and Strobe Wiring Diagrams” on page 26 for instructions.

---

## **Relays**

The Beacon 410A includes eight channel relays and one common fail relay. It also includes four common/channel relays that can be defined as a group as channel or common relays. All the relays have single-pole double-throw (SPDT) contacts, also known as form C contacts, and are rated for 10 amps at 115/220 VAC (resistive) or 10 amps at 30 VDC (resistive). The contacts are available at the channel alarm and common/channel alarm terminal strips and are labeled NO (normally open), NC (normally closed), and C (common).

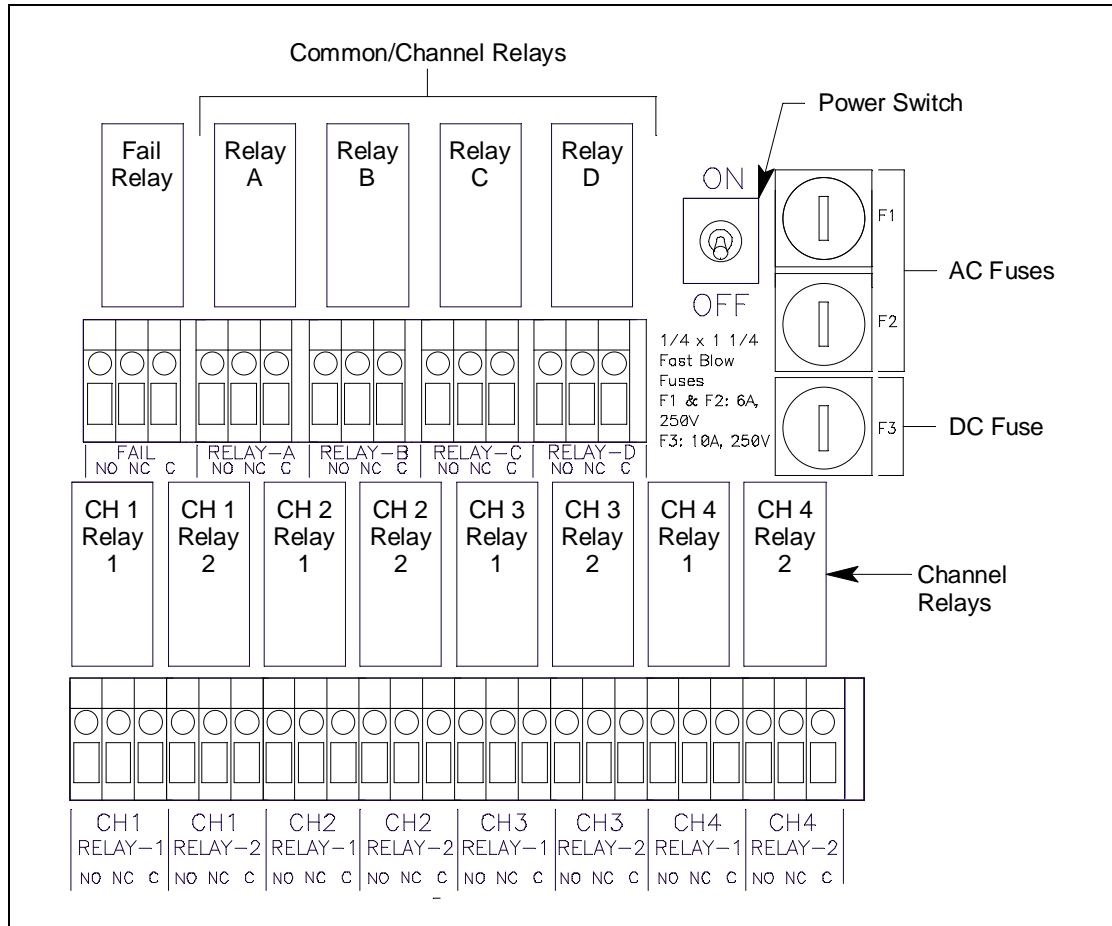

**Figure 5: Beacon 410A Relay Allocation**

- **Channel Relays & Fail Relay**

The eight channel relays are above the channel alarm terminal strip (see Figure 4 on page 13 and Figure 5 on page 16). These relays are dedicated to specific channels. Figure 3 illustrates the allocation of the channel relays.

The fail relay is located directly to the left of the channel relays. The fail relay is a common relay.

- **Common/Channel Relays**

The four common/channel relays are above the common/channel alarm terminal strip (see Figure 4 on page 13 and Figure 5 on page 16). These relays can be configured as either all channel relays or all common relays in the Global Menu.



## **Termination Jumper**

A two pin header with a termination jumper installed is located along the right edge of the main PCB a short distance above the AC In terminal strip. It is labeled “P3” and “RS-485 Terminator” on the PCB silkscreen. Although this jumper has no function unless the Beacon 410A is wired into a Modbus installation, leave it installed unless directed to remove it for a Modbus installation. See “Chapter 9: RS-485 Modbus Output” on page 71 for instructions to use the Beacon 410A in a Modbus system.

## **Ground Jumper**

A two pin header with a jumper installed is located along the right edge of the main PCB just above the termination jumper. It is labeled “P3” on the PCB silkscreen. Leave this jumper installed unless directed to remove it for a Modbus installation. See “Chapter 9: RS-485 Modbus Output” on page 71 for instructions to use the Beacon 410A in a Modbus system.

## **Ground Studs**

Two ground studs are located in the bottom right corner of the main PCB. The left one is unlabeled and is for factory grounding connections. The one on the right is labeled with a ground symbol and is for the field ground connection. A kep nut on the field grounding stud may be removed for installation of one or more user supplied lugs to make wiring connections to earth ground. This stud is typically used to connect the shield drain wire of shielded cable to earth ground at the Beacon 410A.

## **Power Switch**

The power switch is between the common/channel relays and the fuses (see Figure 4 on page 13 and Figure 5 on page 16). The power switch turns the incoming AC power source on and off at the Beacon 410A. When the switch is up, the power is on.

## **Power Supply**

The power supply is mounted to the power supply mounting plate which is located behind the display PCB. The power supply mounting plate is mounted to the main PCB with four standoffs. The power supply receives AC power from the external power source and converts it to a DC voltage that is usable by the Beacon 410A circuitry. A polycarbonate cover prevents accidental contact with the AC terminals on the power supply.

## **Fuses**

Two AC fuses and one DC fuse are used in the Beacon 410A. The fuses are located on the right side of main PCB, between the power switch and the AC in terminal strip (see Figure 4 on page 13 and Figure 5 on page 16). The AC fuses are labeled F1, F2 and the DC fuse is labeled F3 on the PCB silkscreen. They cut off the incoming AC or DC power in the event of a short circuit or other electrical fault which causes a high current draw in the Beacon 410A. They are housed in vertical fuse holders and are held in each holder by a quarter turn cover. The AC fuses are rated at 6 A, 250 V, 1/4 x 1 1/4 inch, fast acting. The DC fuse is rated at 10A, 250V, 1/4 x 1 1/4 inch, fast acting.

# Optional Accessories

This section describes the optional accessories available for the Beacon 410A. Both optional accessories are wired to the Strobe Terminal Strip as shown below.

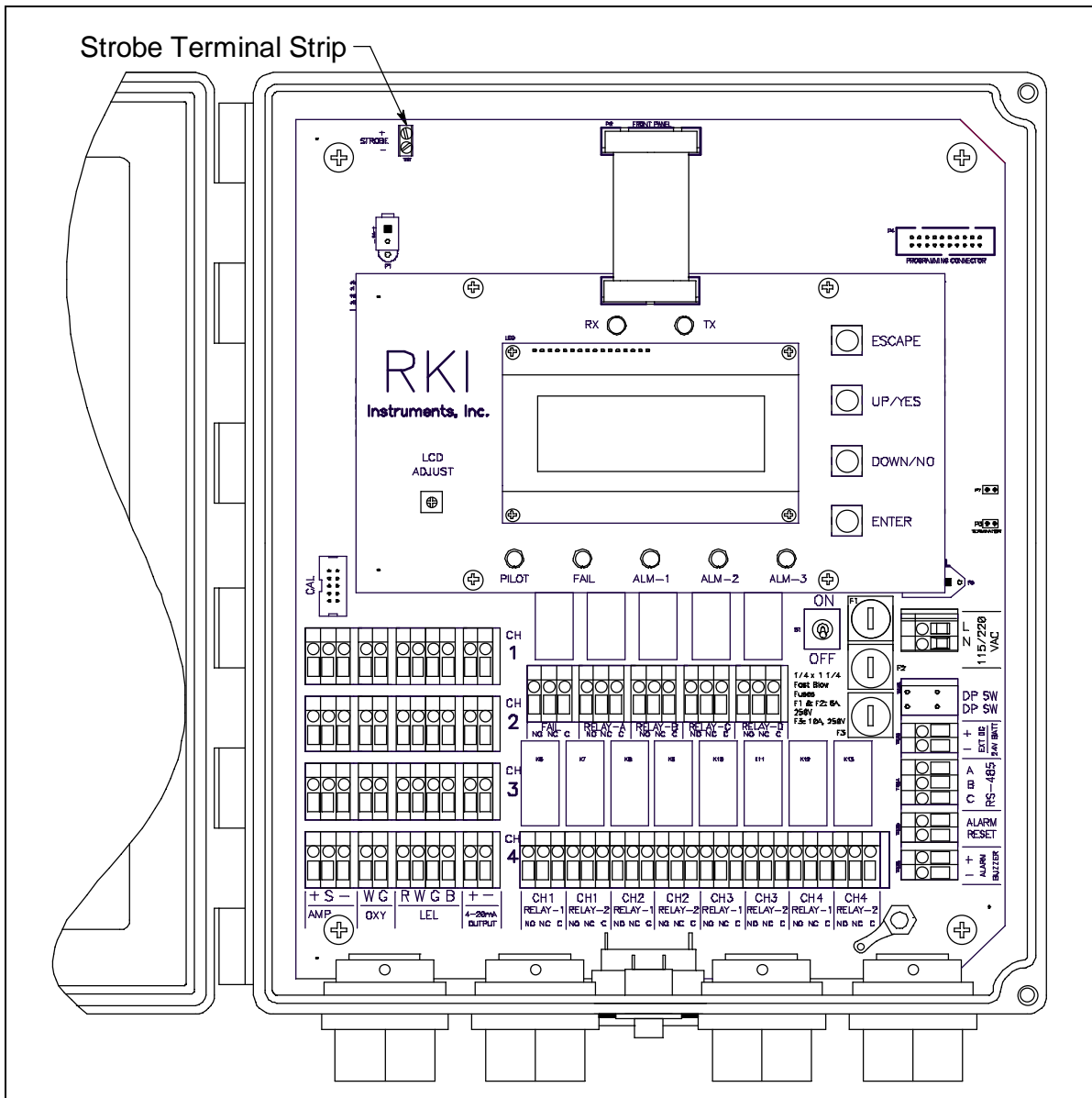

**Figure 6: Strobe Terminal Strip Location**

## Alarm Strobe

The Beacon 410A can be ordered with an alarm strobe light installed on the top of the housing. The Beacon 410A retains its NEMA 4X rating with the strobe installed. Strobe operation can be programmed in Configuration Mode (see “Chapter 6: Configuration Menu” on page 50). The outline and mounting dimensions with the alarm strobe are the same as the standard Beacon 410A with the exception of the height. The difference is shown below. See Figure 9 for all outline and mounting dimensions.

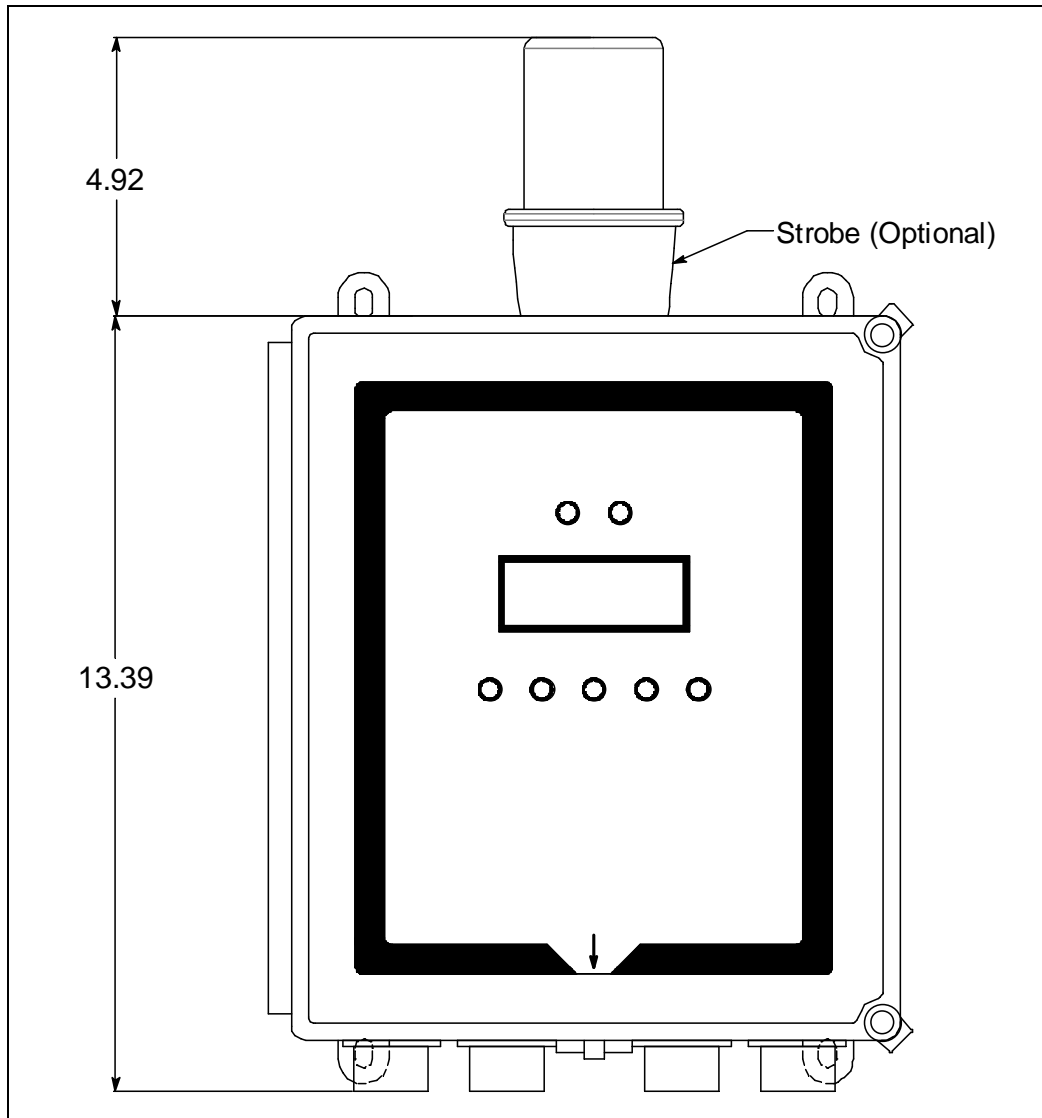

Figure 7: Alarm Strobe Dimensions

## **Horn/Strobe**

The Beacon 410A can be ordered with a horn/strobe. This optional horn/strobe allows the user to have both a strobe and a horn connected to the “Strobe” terminals of the Beacon 410A. If the horn/strobe is not factory installed, it also allows the user to mount the horn/strobe away from the Beacon 410A so that it can be somewhere more visible/audible. Strobe operation can be programmed in Configuration Mode (see “Chapter 6: Configuration Menu” on page 50).

---

**NOTE:** See “Chapter 3: Installation and Start Up” on page 22 for complete Beacon 410A installation instructions.

---

---

**CAUTION:** *Do not adjust the strobe brightness or the horn volume at the strobe/horn, as this may overload the Beacon 410A strobe control circuit.*

---

The optional horn/strobe is generally not factory installed and needs to be installed by the user. The following instructions describe the installation of the horn/strobe. If the horn/strobe is factory installed, the following instructions do not apply.

1. Mount the horn/strobe in the desired location.
2. Install an appropriately rated cable bushing or conduit to the left conduit hub on the bottom of the Beacon 410A housing.
3. Install an appropriately rated cable bushing or conduit at the horn/strobe.
4. Run a cable or wires in conduit from the horn/strobe to the Beacon 410A through the left conduit hub.

5. Connect the wires to the strobe terminal strip as shown in the figure below.

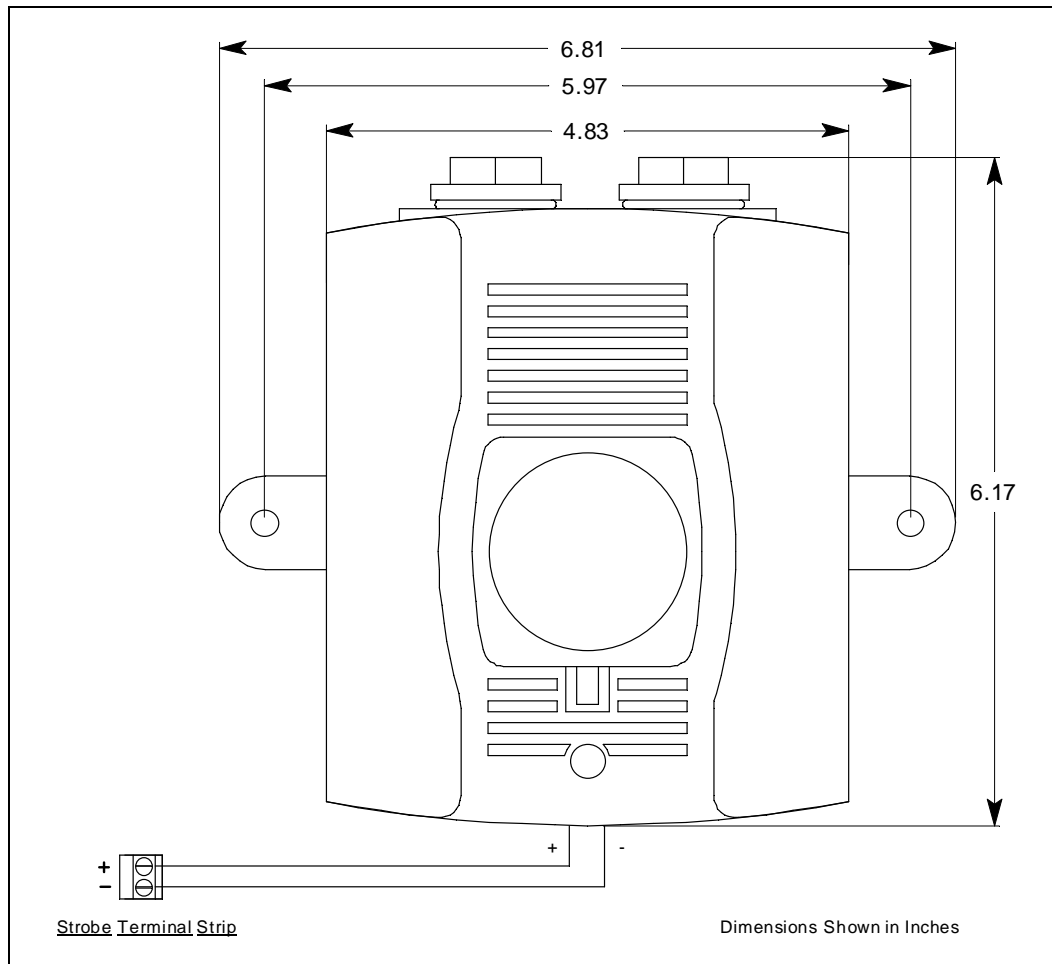

**Figure 8: Horn/Strobe Wiring/Outline and Mounting Dimensions**

# Chapter 3: Installation and Start Up

---

## Overview

This chapter describes procedures to mount the Beacon 410A Gas Monitor, make wiring connections to the monitor, and start up the monitor.

---

**WARNING:** *Perform all installation and start-up procedures in a known fresh air environment, an environment free of combustible and toxic gasses and of normal oxygen content. The Beacon 410A is not in operation as a gas monitoring controller until the start up procedure is complete.*

---

---

## Mounting the Beacon 410A Gas Monitor

---

**WARNING:** *Only authorized and properly trained personnel should perform any mounting procedures.*

---

Perform the following procedure to install the Beacon 410A at the mounting site.

1. Select the mounting site. When you select the mounting site, consider the following factors:
  - Is an AC or DC power source available?
  - Is a vertical surface available to mount the Beacon 410A?
  - Is there enough room to open the housing door and make wiring connections through the conduit hubs at the bottom of the housing?
  - Are the display screen and status lights visible?
2. Close and latch the housing door.
3. The Beacon 410A is shipped with the mounting feet positioned under the housing. Loosen the screws that secure the feet to the housing, rotate the feet to their mounting position as shown in Figure 9, then tighten the screws.
4. Prepare the selected mounting site as required to mount the Beacon 410A. It should be mounted at eye level (4 1/2 to 5 feet from the floor). Refer to Figure 9 for the outline and mounting dimensions.
5. Position the monitor on the vertical mounting surface.
6. Insert 1/4 in. screws through the slots in the mounting feet at each corner of the housing to secure the housing to the mounting surface.
7. Each of the door clamps has a feature for locking device installation. A locking device that requires a tool to unlock must be installed in each door clamp.

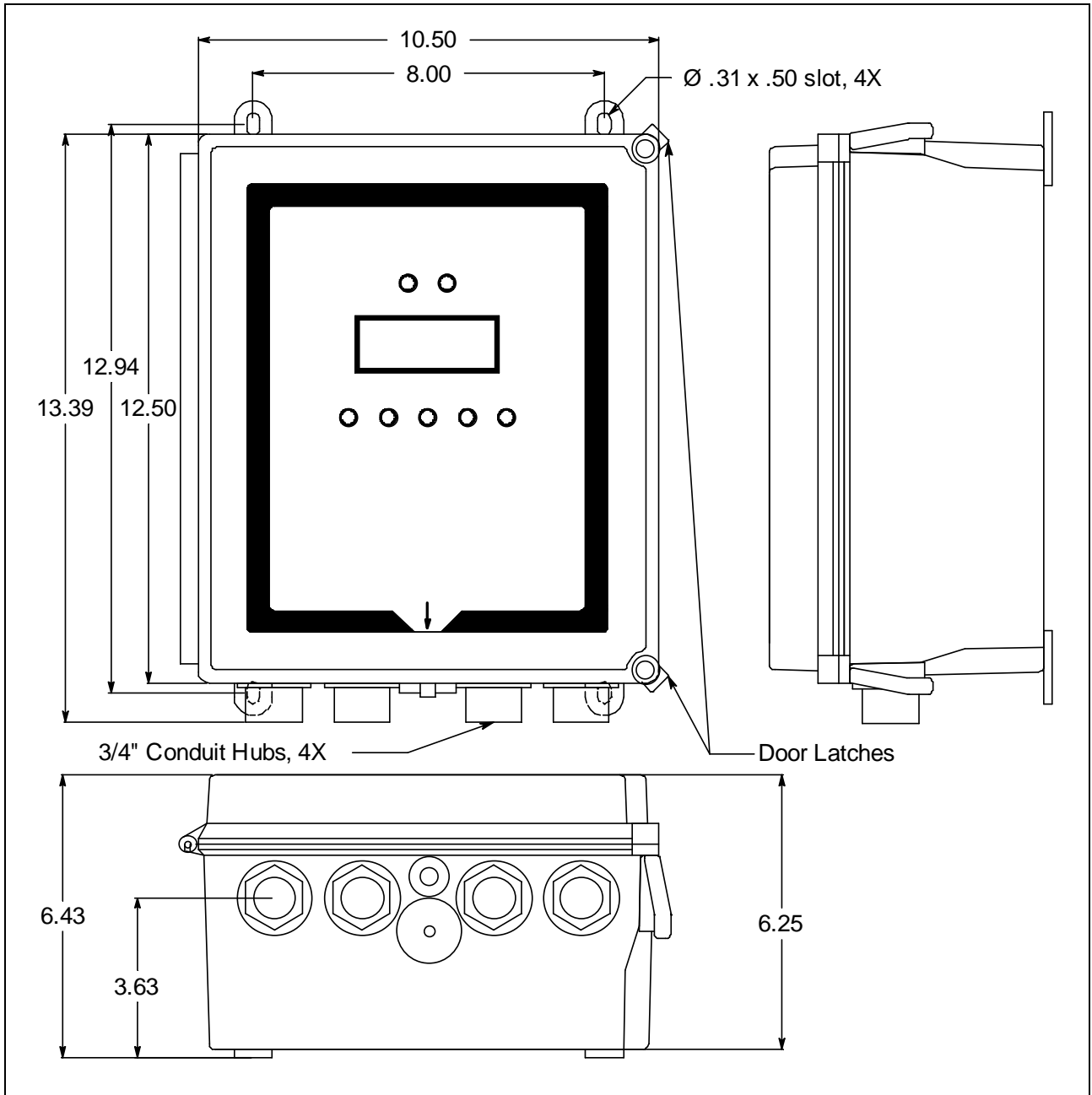

**Figure 9: Beacon 410A Gas Monitor Outline and Mounting Dimensions**

# Wiring the Beacon 410A Gas Monitor

This section describes procedures to connect the AC power source, DC power source, Modbus wiring (refer to “Wiring the Beacon 410A in a Modbus System” on page 71), external alarms, recording devices, and detector heads. See Figure 10 on page 24 for a general diagram of all external wiring to the Beacon 410A.

**WARNING:** *Make all connections to the Beacon 410A before you plug in or turn on the AC or DC power source. Before you make any wiring adjustments, always verify that all power sources are not live.*

## Routing Wiring Into the Beacon 410A Housing

Wiring must be brought into the housing through one of the four factory-installed conduit hubs on the bottom of the housing.

Do not drill into the Beacon 410A housing for any reason. Drilling the Beacon 410A housing and routing wiring through holes not factory drilled will void the warranty and could result in:

- Damage to internal components from the drilling process.
- Moisture damage to internal components from poorly sealed holes.
- Unpredictable Beacon 410A behavior due to EMI/RFI interference caused by wires routed across the PCBs.
- Possible shorting of Beacon 410A components due to wires routed across the PCBs.

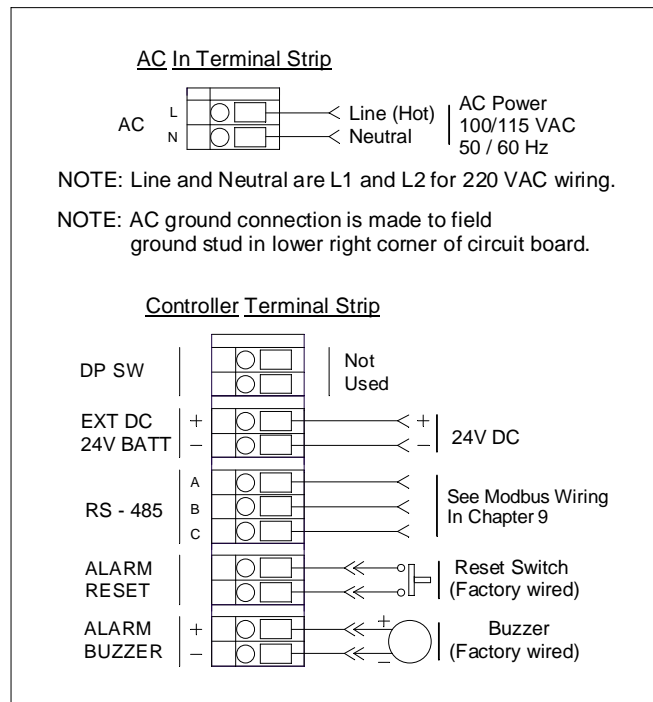
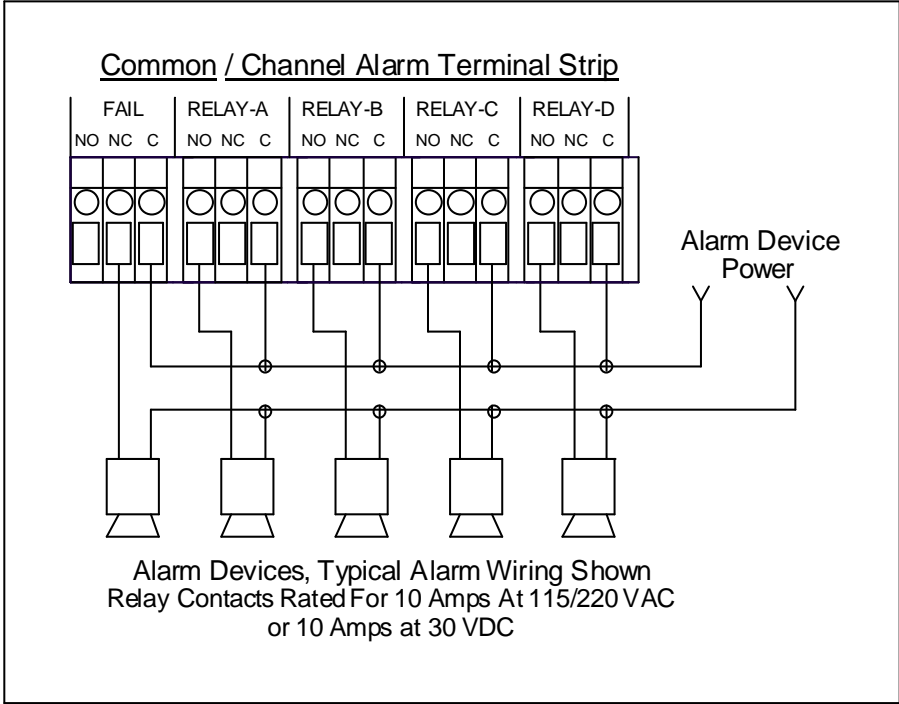
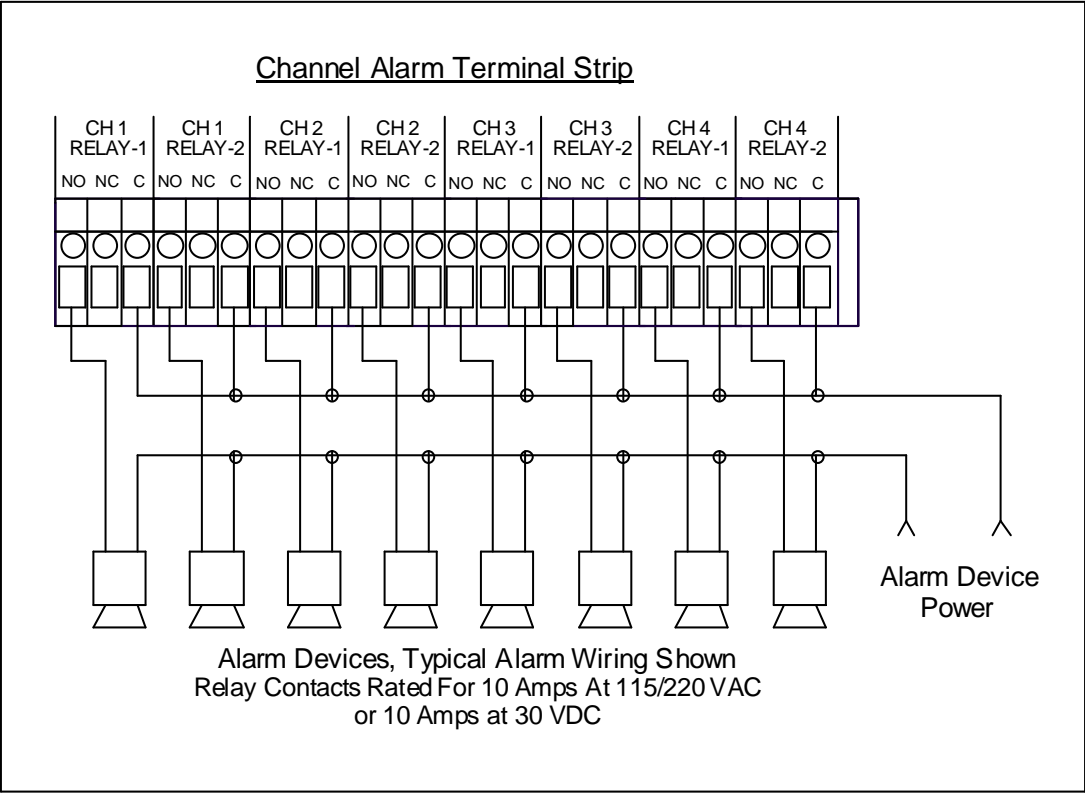

Figure 10: AC Power and Controller Terminal Wiring Diagrams





**Figure 11: Channel and Alarm Terminal Wiring Diagrams**

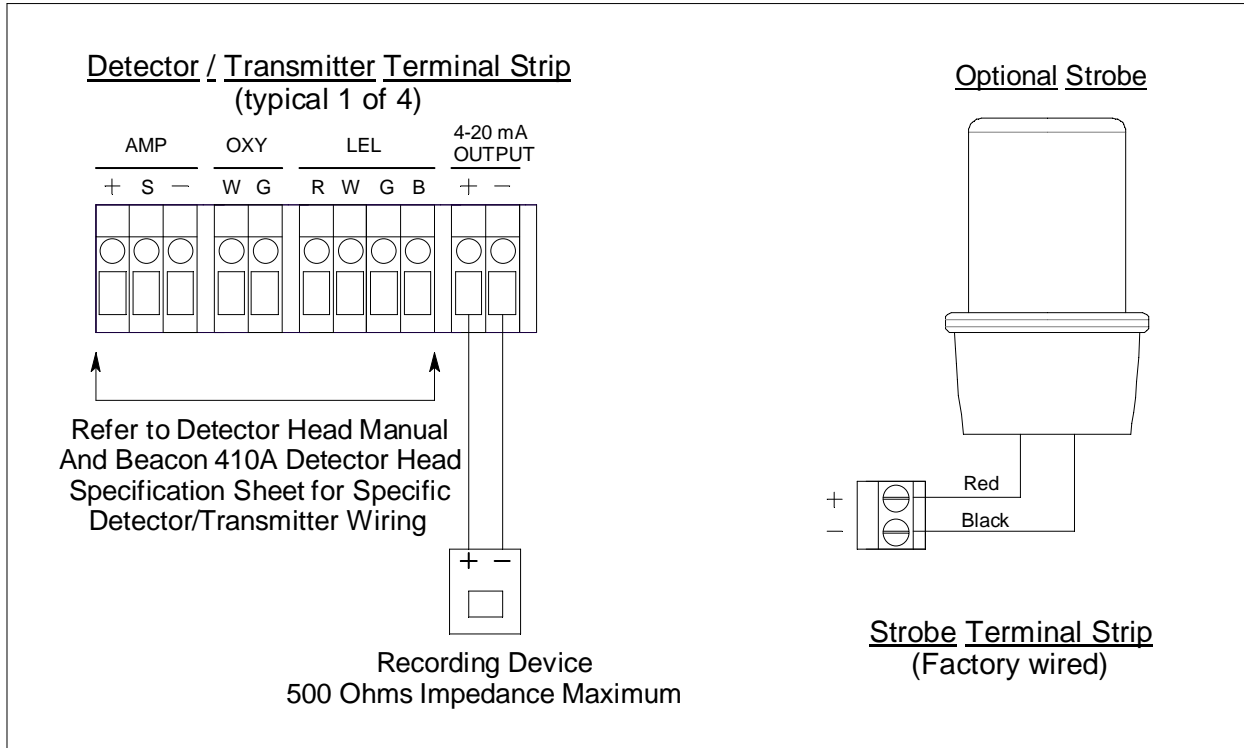

Figure 12: Detector/Transmitter and Strobe Wiring Diagrams

## Connecting the AC Power Source

**NOTE:** If you are using DC power as the primary power source, go to the next section, “Connecting the DC Power Source”.

The AC in terminal strip will accept 24 - 14 AWG wire. For 115 VAC connection, select wire that is sized appropriately for the power requirements of the connected device and that is rated to a minimum of 80°C and 150 V. For 220 VAC connection, select wire that is sized appropriately for the power requirements of the connected device and that is rated to a minimum of 80°C and 250 V. When selecting wire, be sure to meet the local electrical code.

A certified switch or circuit breaker must also be installed in the AC line. For 115 VAC connection, the switch or circuit breaker must be rated to 115 VAC, 50/60 Hz, and 0.5 A. For 220 VAC connection, the switch or circuit breaker must be rated to 220 VAC, 50/60 Hz, and 0.3 A.

Perform the following procedure to connect the AC power source to the Beacon 410A.

**WARNING:** *Verify that the power source is unplugged or turned off before you continue with this procedure.*

1. Turn off or disconnect mains power to the Beacon 410A.

2. Open the housing door, then place the power switch in the OFF position.

---

**CAUTION:** *The power switch does not control DC input power.*

---

3. Locate the AC in terminal strip (see Figure 2 on page 10). The terminals are labeled **L** and **N** for line and neutral respectively.
4. Install an appropriately rated cable bushing or conduit in the right-most conduit hub on the bottom of the Beacon 410A housing.

---

**CAUTION:** *Only use the four factory installed conduit hubs on the bottom of the housing for wire entry into the housing. Do not drill the housing for any reason. See “Routing Wiring Into the Beacon 410A Housing” on page 24 for more information.*

---

5. Guide the AC power cord or wires in conduit through the right-most conduit hub on the bottom of the Beacon 410A housing.

---

**CAUTION:** *Do not route power and detector head wiring through the same conduit hub. The power wiring may disrupt the transmission of the detector head signal to the monitor.*

---

6. Connect the AC wires to the AC in terminal strip as shown in Figure 13 below.

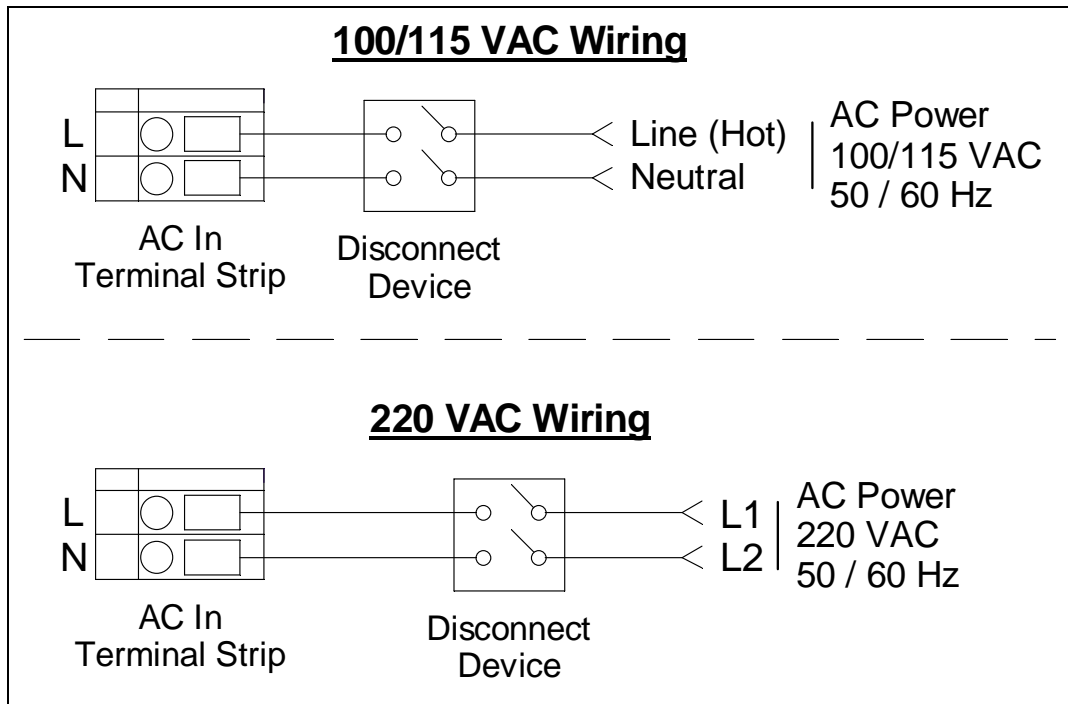

**Figure 13: AC Power Wiring**

7. Connect the ground wire to the crimp terminal that is factory installed on the field ground stud. The field ground stud is located in the lower right corner of the main PCB and is marked with a ground symbol. See Figure 2 on page 10. A factory ground stud is located just to the left of the field ground stud and is not for field use.
  - a. Remove the lug from the field ground stud. There is only 1 lug on the stud.
  - b. Crimp the ground wire to the lug.
  - c. Reinstall the lug.

---

**WARNING:** *Follow this grounding procedure to maintain the CSA classification of the Beacon 410A.*

---

## Connecting the DC Power Source

---

**WARNING:** *Verify that the power source is unplugged or turned off before you continue with this procedure.*

---

DC power may be used as a primary power source. If DC power (connected to the 24 VDC terminals) is the **primary** power source, **DO NOT** connect AC power to the AC In terminal strip. A 24 VDC battery (connected to the 24 VDC terminals) may also be used as a backup power source if AC power (connected to the AC In terminal strip) is the primary power source. If your Beacon 410A does not include the battery charging feature, you may use a self contained 24 VDC backup that keeps its batteries charged while AC power is on and recharges the batteries when AC power returns after a power failure. If your Beacon 410A includes the battery charging feature, see “Battery Charging (Optional)” on page 39 for a complete description of this feature and what type of battery to use.

The controller terminal strip will accept 24 - 14 AWG wire. Select wire that is sized appropriately for the power requirements of the connected device and that is rated to a minimum of 80°C and 150 V. When selecting wire, be sure to meet the local electrical code.

---

**WARNING:** *The 24 VDC terminals are only intended for connecting a battery or a 24 VDC supply to the Beacon 410A. Do not connect any horns or strobes to the 24 VDC terminals.*

---

1. Turn off or disconnect mains power to the Beacon 410A.
2. Open the housing door, then place the power switch in the OFF position.

---

**CAUTION:** *The power switch does not control DC input power.*

---

3. Locate the DC input power terminals on the controller terminal strip near the lower right edge of the main PCB (see Figure 2 on page 10). They are labeled **EXT DC/24V BATT+** and **EXT DC/24V BATT -**.

4. Install an appropriately rated cable bushing or conduit in an unused conduit hub on the bottom of the Beacon 410A housing.

---

**CAUTION:** Only use the four factory installed conduit hubs on the bottom of the housing for wire entry into the housing. Do not drill the housing for any reason. See “Routing Wiring Into the Beacon 410A Housing” on page 24 for more information.

---

5. Guide a DC power cord or two wires in conduit through the selected conduit hub on the bottom of the Beacon 410A housing.

---

**CAUTION:** Do not route power and detector head wiring through the same conduit hub. The power wiring may disrupt the transmission of the detector head signal to the monitor.

---

6. Connect the DC power wires to the controller terminal strip as shown in Figure 14 below.

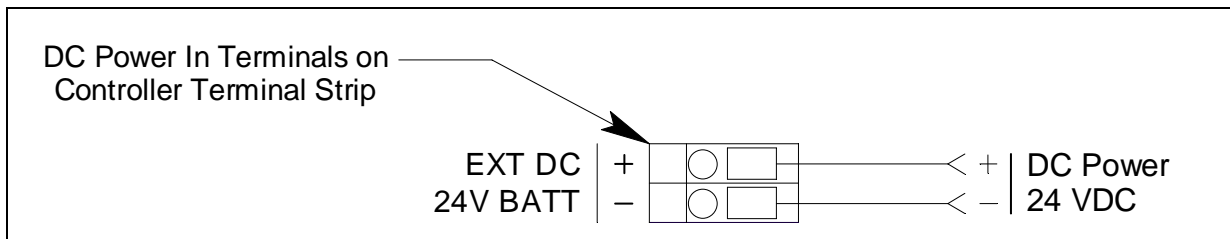

**Figure 14: DC Power Wiring**

---

**NOTE:** The Beacon 410A will operate from the DC input down to 18.5 volts. If a self contained backup battery is used, see its operator’s manual for a description of its recharging characteristics. If your Beacon 410A includes the battery charging feature and a backup battery is used, the Beacon 410A will recharge the battery when AC power has returned after a power failure. See “Battery Charging (Optional)” on page 39. for a complete description of the battery charging feature.

---

## RS-485 Modbus Wiring

See “Wiring the Beacon 410A in a Modbus System” on page 71 for wiring connections to the RS-485 Modbus terminals.

## Connecting External Alarms

Before connecting any external alarm devices to the relay contacts, make sure you know how you want the devices to operate. For example, confirm under what alarm condition you want a device to turn on or turn off and what channel is going to control the device. Also make sure that the parameter settings that apply to the relays in the Global Menu and the Configuration Menu are set so that the desired alarm device operation is obtained. See “Viewing and Changing Global Parameters” on page 47 and “Viewing and Changing Channel Parameters” on page 50 for information about the relay parameters.

The relays are rated for 10 amps at 115/220 VAC (resistive) or 10 amps at 30 VDC (resistive). The alarm terminals will accept 24 - 14 AWG wire. Select wire that is sized appropriately for the power requirements of the connected device and that is rated to a minimum of 80°C and up to 250 V depending on the device being powered.

---

**WARNING:** *Do not connect external alarms to the 24 VDC terminals.*

---

Perform the following procedure to connect external alarm devices to the Beacon 410A.

1. Turn off or disconnect mains power to the Beacon 410A.
2. Open the housing door, then place the power switch in the OFF position.

---

**CAUTION:** *The power switch does not control DC input power.*

---

3. Locate the applicable alarm terminal strip (see Figure 2 on page 10).
4. Install an appropriately rated cable bushing or conduit in an unused conduit hub on the bottom of the Beacon 410A.

---

**CAUTION:** *Only use the four factory installed conduit hubs on the bottom of the housing for wire entry into the housing. Do not drill the housing for any reason. See “Routing Wiring Into the Beacon 410A Housing” on page 24 for more information.*

---

5. Guide the wiring of the external alarm device through the selected conduit hub on the bottom of the Beacon 410A housing.

---

**CAUTION:** *Do not route the external alarm wiring and detector head wiring through the same conduit hub. The external alarm wiring may disrupt the transmission of the detector head signal to the Beacon 410A.*

---

6. Connect the leads from the external alarm device and an external power source to the selected channel alarm or common/channel alarm relay contact terminals as shown in Figure 8.

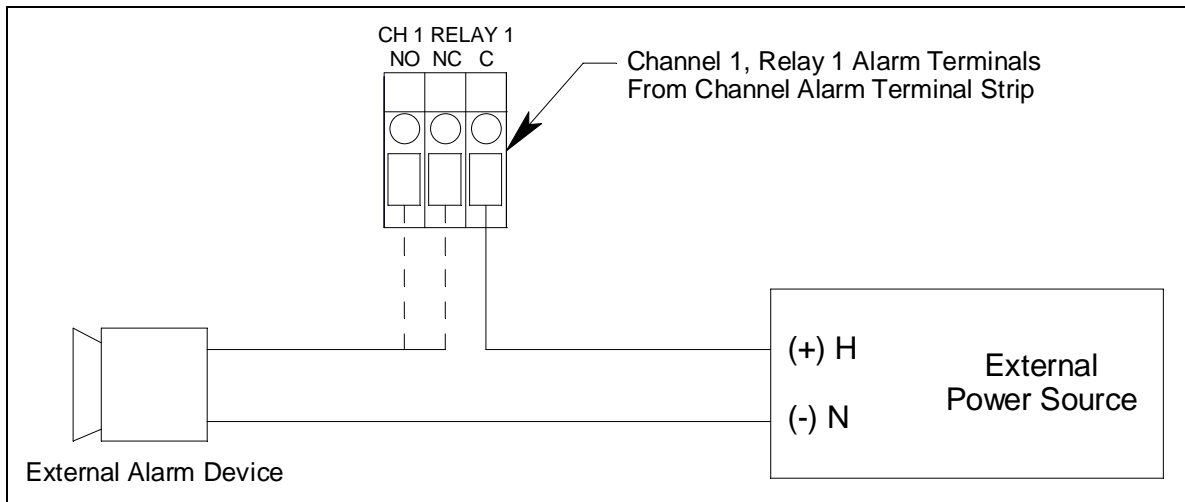

**Figure 15: External Alarm Wiring**

7. Repeat Step 5 and Step 6 for additional external alarm devices.

## ***Connecting Recorders***

Perform the following procedure to connect an analog signal recording device to the Beacon 410A. The output at the recorder output terminals for each channel is a 4 - 20 mA signal that corresponds to the detection range of the detector head connected to that Beacon 410A channel. Be sure to read the recording device's operator's manual before installation and follow all wiring procedures and recommendations made by the recording device's manufacturer.

The recorder output terminals will accept 24 - 14 AWG wire. Select wire that is sized appropriately for the power requirements of the connected device and that is rated to a minimum of 80°C and 150 V.

1. Turn off or disconnect mains power to the Beacon 410A.
2. Open the housing door, then place the power switch in the OFF position.

---

***CAUTION:*** *The power switch does not control DC input power.*

---

3. Locate the recorder output terminals on the right end of the detector/transmitter terminal strips. See "Beacon 410A Gas Monitor Internal Component Location" on page 10 to assist you in locating the recorder output terminals. They are labeled **4 - 20 mA OUTPUT +** and **4 - 20 mA OUTPUT -**.

4. Install an appropriately rated cable bushing or conduit in an unused conduit hub on the bottom of the Beacon 410A housing.

---

**CAUTION:** Only use the four factory installed conduit hubs on the bottom of the housing for wire entry into the housing. Do not drill the housing for any reason. See “Routing Wiring Into the Beacon 410A Housing” on page 24 for more information.

---

5. Guide the wiring from the recording device through the selected conduit hub on the bottom of the Beacon 410A housing.
6. Connect the leads from the recording device to the recorder output terminals of the selected active channels as shown in Figure 16 below.

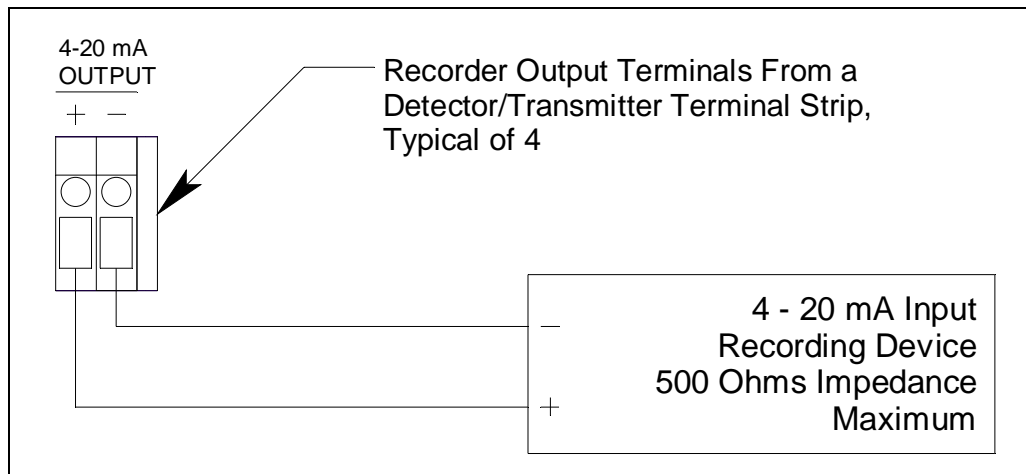

**Figure 16: Recorder Output Wiring**

## Connecting RKI Detector Heads

When a Beacon 410A is ordered from the factory, any detector heads that were ordered with it are already setup on particular channels of the Beacon 410A. If you are adding an RKI detector head to your existing system, you will need to setup one of the unused channels to operate the detector head. See “Selecting the Detector Head Input Type and Gas Setup” on page 57 for instructions to setup a new channel.

The detector/transmitter terminals will accept 24 - 14 AWG wire. Select wire that is sized appropriately for the power requirements of the connected device and that is rated to a minimum of 80°C and 150 V.

Perform the following procedure to connect an RKI detector head to the Beacon 410A.

1. Turn off or disconnect mains power to the Beacon 410A.
2. Open the Beacon 410A door and place the power switch in the off position.

---

**CAUTION:** The power switch does not control DC input power.

---

3. See the detector head operator’s manual for instructions on how to connect the detector head to a controller.



4. Install an appropriately rated cable bushing or conduit in an unused conduit hub on the bottom of the Beacon 410A housing.

---

**CAUTION:** *Only use the four factory installed conduit hubs on the bottom of the housing for wire entry into the housing. Do not drill the housing for any reason. See “Routing Wiring Into the Beacon 410A Housing” on page 24 for more information.*

---

5. Route the wires in conduit or shielded cable from the detector head through the selected conduit hub into the Beacon 410A. See Table 5 below for wire size and distance guidelines.
6. Unshielded twisted pair cable in conduit or shielded twisted pair cable is recommended for all the direct connect detector heads. For the LEL detector, pair and twist the **R & B** wires and the **W & G** wires. Shielded cable or wires in conduit are recommended for the 2-wire and 3-wire 4 - 20 mA transmitters.
7. Connect the wires from the detector head to the appropriate detector/transmitter terminals on the appropriate channel. See the detector head operator’s manual and the Beacon 410A Detector Head Specification Sheet for detector head connections to the Beacon 410A. If shielded cable is used, leave the cable shield’s drain wire disconnected and insulated at the detector head and connect the cable shield’s drain wire at the Beacon 410A to the ground stud on the main PCB.

---

**CAUTION:** *Do not route power and detector head wiring through the same conduit hub. The power wiring may disrupt the transmission of the detector head’s signal to the Beacon 410A.*

---

**Table 5: Wire Size Guidelines for RKI Detector Head Wiring**

Detector Head Type	Number of Wires to Controller	Max Distance to Controller w/18 Gauge Wire	Max Distance to Controller w/16 Gauge Wire	Max Distance to Controller w/14 Gauge Wire
Direct Connect LEL	4	500 ft.	1,000 ft.	2,000 ft.
Direct Connect Oxygen	2	500 ft.	1,000 ft.	2,000 ft.
Direct Connect H2S	2	500 ft.	1,000 ft.	2,000 ft.
Direct Connect CO	2	500 ft.	1,000 ft.	2,000 ft.
Direct Connect ESM-01 type	2	500 ft.	1,000 ft.	2,000 ft.
2-Wire 4 - 20 mA Transmitter	2	2,500 ft.	5,000 ft.	8,000 ft.
3-Wire 4 - 20 mA Transmitter	3	2,500 ft.	5,000 ft.	8,000 ft.

## Connecting User-Supplied 4 - 20 mA Transmitters

The Beacon 410A may be used with a user supplied 2-wire or 3-wire 4 - 20 mA transmitter which runs on 24 VDC. When this is done, the Beacon 410A is normally setup at RKI Instruments with the following channel parameters: unit of measure, item name, and full scale. For example, “PSI AIR” with a full scale of 10 PSI.

If a user supplied 4 - 20 mA transmitter is added in the field, it will be necessary to setup the additional channel. See “Selecting the Detector Head Input Type and Gas Setup” on page 57 for instructions to setup a new channel.

The detector/transmitter terminals will accept 24 - 14 AWG wire. Select wire that is sized appropriately for the power requirements of the connected device and that is rated to a minimum of 80°C and 150 V.

Perform the following procedure to connect a 4 - 20 mA transmitter which you supply to the Beacon 410A.

1. Turn off or disconnect mains power to the Beacon 410A.
2. Open the Beacon 410A door and turn off the power switch.

---

**CAUTION:** *The power switch does not control DC input power.*

---

3. See the transmitter’s operator’s manual for instructions on how to connect wires to the transmitter.
4. Install an appropriately rated cable bushing or conduit in an unused conduit hub on the bottom of the Beacon 410A housing.

---

**CAUTION:** *Only use the four factory installed conduit hubs on the bottom of the housing for wire entry into the housing. Do not drill the housing for any reason. See “Routing Wiring Into the Beacon 410A Housing” on page 24 for more information.*

---

5. Route the wires from the transmitter through the selected conduit hub into the Beacon 410A.

6. Connect the wires from the transmitter to the appropriate channel's detector/transmitter terminal strip. See the transmitter operator's manual for controller terminal connections and wiring recommendations.

---

**CAUTION:** Do not route power and transmitter wiring through the same conduit hub. The power wiring may disrupt the transmission of the transmitter's signal to the Beacon 410A.

---

Figure 17 illustrates typical transmitter wiring connections.

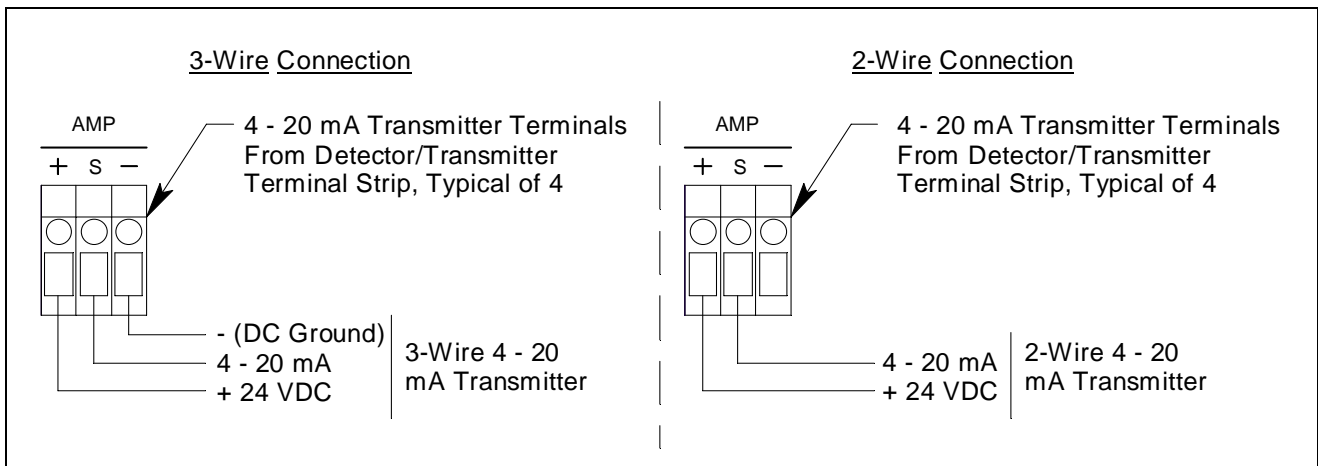

Figure 17: Generic 4 to 20 mA Transmitter Wiring

## Starting Up the Beacon 410A Gas Monitor

Perform the following procedure to place the Beacon 410A into normal operation.

1. Complete the mounting and wiring procedures described earlier in this chapter.
2. Complete all installation procedures described in the detector head or user supplied 4 - 20 mA transmitter operator's manuals.
3. Verify that all wiring connections are correct and secure and that the Beacon 410A's power switch is in the OFF position.
4. Plug in or turn on the incoming power source (AC or DC).
5. Turn on the power switch if AC power is used as primary power.
6. The following screen appears for a few seconds.

```
R K I   I n s t r u m e n t s
B e a c o n   4 1 0
```

- The Version Screen then appears. It shows the instrument's hardware and firmware versions for a few seconds. HW is the hardware version. Main is the main firmware version. MB is the Modbus firmware version. The version numbers on the bottom line are the firmware versions loaded for each channel.

V E R S I O N				I N F O			
HW :	0	0	0	0			
Main :	0	0	0	1	MB :	0	0
	0	0	0	1		0	0
	0	0	0	1		0	0
	0	0	0	1		0	0
	0	0	0	1		0	0

To keep the version information screen on the display longer than a few seconds, press and hold the ENTER button while it is being displayed. When you release the ENTER button, the startup sequence will continue.

- After the Version Screen has been displayed for a few seconds, **WARMING UP** appears for each active channel. The warm-up time is counted down in seconds from 60 seconds for each active channel on the far right.

---

**NOTE:** To prevent unwanted alarms during warm up, the alarm circuits are not active while the **WARMING UP** message is displayed.

---

- Any unused channels are configured as **NOT USED** in the Configuration Menu at the factory. For any unused channels, **NOT USED** is displayed on the line for that channel. If any channels have been configured as **STANDBY** in the Configuration Menu, **STANDBY** is displayed on the line for that channel. See “Viewing and Changing Channel Parameters” on page 50 for a description of the **NOT USED** and **STANDBY** configurations.
- When the warm-up period is complete, normal operation will begin. During normal operation, the display will indicate the current gas reading and target gas. Verify that the display is indicating the current gas reading and target gas for all active channels after the warm-up period is complete and normal operation begins, for example:

1 :	M E T H A N E	0	% L E L
2 :	O X Y G E N	2 0 . 9	% V O L
3 :	H 2 S	0	p p m
4 :	C O	0	p p m

- Verify that the PILOT light is on. If the PILOT light is not on, see the troubleshooting guide in “Troubleshooting” on page 81.
- Perform the start-up procedure for each detector head or user supplied 4 - 20 mA transmitter as described in the detector head or user supplied transmitter's operator's manual.

# Chapter 4: Operation

---

## Overview

This chapter describes the Beacon 410A Gas Monitor in normal operation. This chapter also describes the Beacon 410A in alarm 1, alarm 2, alarm 3, and fail conditions, and suggests responses to these conditions.

---

## Normal Operation

Normal operation is defined as follows:

- the start-up procedure is complete.
- the Beacon 410A is not indicating an alarm 1, alarm 2, alarm 3, or fail condition.
- the Beacon 410A is not running in one of the selection menus or Calibration Mode.

During normal operation, the Beacon 410A simultaneously displays the target gas, unit of measure, and current gas reading for all active channels. The example below illustrates a typical Beacon 410A channel allocation.

1	:	M E T H A N E	0	% L E L
2	:	O X Y G E N	2 0 . 9	% V O L
3	:	H 2 S	0	p p m
4	:	C O	0	p p m

The PILOT LED is on indicating that the Beacon 410A is receiving incoming power.

---

## 4 - 20 mA Signal Output Operation

The output at the recorder output terminals on the detector/transmitter terminal strip for each channel is a 4 - 20 mA signal that corresponds to the detection range of the Beacon 410A. During normal operation, this signal tracks the gas concentration on the display.

There are several circumstances where the signal output will not track the display reading but will behave as follows:

- When the Beacon 410A is in its warm-up period, the signal output will be fixed at 4 mA (zero) for all channel types except oxygen. For oxygen channels, the output will be fixed at 17.4 mA (20.9% oxygen) while the Beacon 410A is in warm-up.
- When a channel's input type is changed to a new direct connect type of detector head in the Input Setup Menu, the display will indicate **NEEDS AIR/GAS Cal** for that channel when you exit the Input Setup Menu and enter normal operation and will continue to indicate this until Calibration Mode is entered and a calibration is performed. If a custom gas name and range was defined in the Input Setup Menu, the Beacon 410A will enter the Configuration Menu for you to verify the parameter settings before continuing to the normal operation and displaying the **NEEDS AIR/GAS Cal** message. In this situation, the signal output for the newly configured channel will be fixed at 0.7 mA until a complete calibration is performed on that channel.
- If you enter the Global Menu, the Configuration Menu, the Input Setup Menu, the Modbus Menu, or Calibration Mode, the signal output will be fixed at 3.5 mA until the Beacon 410A returns to normal operation.
- If the Beacon 410A's input power decreases below 18.5 volts so that the Beacon 410A is in a low power alarm, the signal output is fixed at 0.7 mA until the low power alarm is cleared.
- If the Beacon 410A goes into a fail condition, after a 30 second delay, the signal output is fixed at 0.7 mA until the fail alarm is cleared. During the 30 second delay, the output follows the detector output. In the case of a downscale reading, the displayed gas reading will only go as low as -10% of full scale but the signal output will continue to track the reading even if it's lower than -10% of full scale.
- If a channel is setup as **NOT USED**, the signal output will be fixed at about 0.7 mA.
- If a channel is setup as **STANDBY**, the signal output will be fixed at 3.5 mA.

---

## Viewing and Resetting Min/Max Readings

The Reset switch may be used to view and reset the minimum and maximum gas readings for all active channels.

1. While the Beacon 410A is in normal operation, press and hold the reset switch button for 5 seconds.
2. The display will show the following screen for about ten seconds.

1 :	0	0
2 :	2 0 . 9	2 0 . 9
3 :	0	0
4 :	0	0

The minimum reading is on the left and the maximum is on the right for each channel.

3. After the minimum and maximum readings have been displayed for about ten seconds, the following screen appears for about seven seconds.

P	u	s	h	R	e	s	e	t	A	g	a	i	n	T	o		
R	e	s	e	t	M	i	n	/	M	a	x	V	a	l	u	e	s
O	r	W	a	i	t	T	o	R	e	t	u	r	n	T	o		
N	o	r	m	a	l	O	p	e	r	a	t	i	o	n			

- To reset the minimum and maximum readings, before the unit returns to normal operation press and release the reset switch button. The display indicates **Min/Max Values Have Been Reset** and the unit will then return to normal operation.
- To return to normal operation without resetting the minimum and maximum readings, do not press the reset switch button and allow the unit to return to normal operation.

---

## Battery Charging (Optional)

The Beacon 410A has an optional backup battery charging feature. In order for this feature to be included, the Beacon 410A must be ordered with this feature. Consult RKI Instruments, Inc. for ordering information.

The battery charging circuit is designed to charge lead acid type batteries. If AC power is used as primary power and a backup battery is connected to the Beacon 410A 's EXT DC/24V BATT terminals as shown in Figure 14 on page 29, the battery charging feature will charge the battery if it is depleted and keep it charged with a charge current of approximately 100 mA.

---

**CAUTION:** *When a battery is used as backup power and the charging feature is included in the Beacon 410A, do not use a non-rechargeable battery or a backup battery that has it's own charging feature. Use RKI backup battery 49-8104RK or an appropriately rated 24 VDC rechargeable lead acid type battery to backup a Beacon 410A when the battery charging feature is included in the Beacon 410A.*

---

# Alarm Indications

This section describes the Beacon 410A in alarm 1, alarm 2, alarm 3 and fail conditions, and suggests responses to these conditions. Table 6 below lists the alarm indications for each condition.

**NOTE:** The Beacon 410A allows configuration of various alarm and alarm relay parameters. The description of alarm indications below assumes that all parameters are at their factory set value. It also assumes that the alarm setpoints are set such that alarm 1 < alarm 2 < alarm 3 and all alarms are increasing except for an oxygen channel where alarm 1 > alarm 3 and alarm 2 > alarm 3 because alarm 1 and alarm 3 are decreasing alarms and alarm 2 is an increasing alarm.

See “Viewing and Changing Channel Parameters” on page 50. for detailed information on displaying or changing various channel parameters including alarm and alarm relay parameters. Table 8 on page 52 lists the adjustable parameters and their factory settings.

**Table 6: Visual and Audible Alarm Indications**

Condition	Cause	Visual Indication(s)	Audible Indication
Alarm 1	Increasing (decreasing for O <sub>2</sub> ) gas reading at or above the alarm 1 setpoint	<ul style="list-style-type: none"> <li>Alarm 1 LED is on</li> <li>Gas reading alternates with <b>ALARM-1</b> message</li> <li>If installed and set to activate for alarm 1, strobe flashes</li> </ul>	Pulsing Tone
Alarm 2	Increasing gas reading at or above the alarm 2 setpoint	<ul style="list-style-type: none"> <li>Alarm 1 and alarm 2 LEDs (alarm 2 only for oxygen) are on</li> <li>Gas reading alternates with <b>ALM 1,2</b> message (<b>ALARM-2</b> for oxygen)</li> <li>If installed, strobe continues to flash if set to activate for alarm 1. If set to activate for alarm 2 only or if channel in alarm is an oxygen channel, it begins to flash when an alarm 2 condition begins.</li> </ul>	Pulsing Tone



**Table 6: Visual and Audible Alarm Indications**

Condition	Cause	Visual Indication(s)	Audible Indication
Alarm 3	Increasing (decreasing for O <sub>2</sub> ) gas reading at or above (below for O <sub>2</sub> ) the alarm 3 setpoint	<ul style="list-style-type: none"> <li>• Alarm 1, alarm 2, and alarm 3 LEDs (alarm 1 and alarm 3 for oxygen) are on</li> <li>• Gas reading alternates with <b>ALM 1,2,3</b> (<b>ALM 1,3</b> for oxygen) message</li> <li>• If installed, strobe continues to flash if set to activate for alarm 1 and/or alarm 2 for non oxygen type channels or alarm 1 for oxygen channels. If set to activate for alarm 3 only, it begins to flash when an alarm 3 condition begins.</li> </ul>	Pulsing tone
Fail	<ul style="list-style-type: none"> <li>• Disconnected or misconnected detector head wiring</li> <li>• Display reading below -10% of full scale or lower</li> <li>• Malfunctioning components</li> </ul>	<ul style="list-style-type: none"> <li>• Fail LED is on</li> <li>• <b>FAIL</b> message replaces the gas reading</li> <li>• If installed and set to activate for fail, strobe flashes There is a 30 second delay on the fail indications.</li> </ul>	Steady tone
Low Battery	No AC power <b>and</b> DC power source (primary or backup) less than 18.5 volts.	<ul style="list-style-type: none"> <li>• FAIL LED is on</li> <li>• Display shows <b>LOW POWER STANDBY</b> message and the input DC voltage</li> </ul>	None

---

**NOTE:** You can set the channel alarm relays and the common/channel alarm relays (relays A, B, C, and D) to be either all normally energized or all normally de-energized in the Global Menu. You can also set relays A, B, C, and D as common alarm relays or channel alarm relays in the Global Menu. The following sections describe the factory settings of normally de-energized for the channel and common/channel relays (A, B, C, and D) and common alarm relays for relays A, B, C, and D. The fail relay is factory-set as normally energized and is not user adjustable. See “Viewing and Changing Global Parameters” on page 47. for instructions to change the setup of relays A, B, C, and D.

---

# **Alarm 1 Condition**

This section describes the indications for an alarm 1 condition and suggests responses to an alarm 1 condition.

## **Alarm 1 Condition Indications**

When the gas reading of an active channel reaches the alarm 1 setpoint, the Beacon 410A senses an alarm 1 condition. The Beacon 410A alerts you to an alarm 1 condition as follows:

- the alarm 1 LED turns on
- the gas reading in alarm 1 condition alternates with the **ALARM-1** message
- the buzzer sounds a pulsing tone
- the common alarm 1 relay (relay A) and relay D energize

---

**NOTE:** Relay D is factory set as a common any alarm relay.

---

- the applicable alarm 1 channel relay energizes
- if installed and set to activate in an alarm 1 condition, the strobe flashes

## **Responding to an Alarm 1 Condition**

This section suggests the following responses to an alarm 1 condition:

1. Follow your established procedure for a low-level combustible or toxic gas condition or a decreasing oxygen condition.
2. To acknowledge the alarm condition and silence the buzzer while in an alarm 1 condition, press and release the reset switch. The alarm 1 LED will begin to flash indicating the alarm condition has been acknowledged. You cannot de-energize the alarm 1 relays until the gas reading falls below (rises above for oxygen) the alarm 1 setpoint.
3. Oxygen alarms are factory set as self-resetting and will automatically clear when the oxygen reading rises above the alarm 1 setpoint.
4. Alarms for all other gas types are factory set as latching. After the gas reading falls below the alarm 1 setpoint, press and release the reset switch to reset the alarm 1 circuit. Resetting the alarm 1 circuit silences the buzzer (if the alarm has not been acknowledged), turns off the alarm 1 LED, resets the display for the channel(s) in alarm, turns off the strobe if it is installed and set to activate for alarm 1, and de-energizes the common and channel alarm 1 relays and relay D.

## ***Alarm 2 Condition***

This section describes the indications for an alarm 2 condition and suggests responses to an alarm 2 condition.

### **Alarm 2 Condition Indications**

When the gas reading of an active channel reaches the alarm 2 setpoint, the Beacon 410A senses an alarm 2 condition. The Beacon 410A alerts you to an alarm 2 condition as follows:

- the ALARM 2 LED turns on
- the gas reading during an alarm 2 condition alternates with the **ALM 1,2 (ALARM-2** for oxygen) message
- the buzzer sounds a pulsing tone
- the common alarm 2 relay (relay B) energizes
- for an oxygen channel, relay D energizes (it is already energized for non-oxygen channels)
- the applicable alarm 2 channel relay energizes
- if installed and set to activate for alarm 1, the strobe continues to flash for non-oxygen channels
- if installed and set to activate for alarm 2 only or for oxygen channels, the strobe begins to flash when an alarm 2 condition begins

### **Responding to an Alarm 2 Condition**

This section suggests responses to an alarm 2 condition.

1. Follow your established procedure for a high-level combustible or toxic gas condition, or an increasing oxygen condition.
2. To acknowledge the alarm condition and silence the buzzer while in an alarm 2 condition, press and release the reset switch. The alarm 2 LED will begin to flash indicating the alarm condition has been acknowledged. You cannot de-energize the alarm 2 relays until the gas reading falls below the alarm 2 setpoint.
3. Oxygen alarms are factory set as self-resetting and will automatically clear when the oxygen reading falls below the alarm 2 setpoint.
4. Alarms for all other gas types are factory set as latching. After the gas reading falls below the alarm 2 setpoint, press and release the reset switch to reset the alarm circuit. Resetting the alarm circuit silences the buzzer (if the alarm has not been acknowledged) turns off the alarm 2 LED, resets the display for the channel(s) in alarm, turns off the strobe if it is installed and set to activate for alarm 2 only or if a channel is an oxygen channel, and de-energizes the common and channel alarm 2 relays. For oxygen channels, the reset switch also de-energizes relay D.

## **Alarm 3 Condition**

This section describes the indications for an alarm 3 condition and suggests responses to an alarm 3 condition.

---

**NOTE:** The factory set configuration of the Beacon 410A does not assign channel relay contacts to the alarm 3 condition. Relays A, B, C, and D are factory set as common alarm relays, but can be configured as channel alarm 3 relays. See “Viewing and Changing Global Parameters” on page 47 and “Viewing and Changing Channel Parameters” on page 50 for instructions to change relays A, B, C, and D from their factory setting.

---

### **Alarm 3 Condition Indications**

When the gas reading of an active channel reaches the alarm 3 setpoint, the Beacon 410A senses an alarm 3 condition. The Beacon 410A alerts you to an alarm 3 condition as follows:

- the alarm 3 LED turns on;
- the gas reading during an alarm 3 condition continues to flash and alternates with the **ALM 1,2,3** (**ALM 1,3** for oxygen) message;
- the buzzer sounds a pulsing tone;
- the common alarm 3 relay (relay C) energizes
- if installed and set to activate for alarm 1 and/or alarm 2 for non-oxygen channels or alarm 1 for oxygen channels, the strobe continues to flash
- if set to activate for alarm 3 only, it begins to flash when an alarm 3 condition begins

### **Responding to an Alarm 3 Condition**

This section suggests responses to an alarm 2 condition.

1. Follow your established procedure for a high-level combustible or toxic gas condition, or an increasing oxygen condition.
2. To acknowledge the alarm condition and silence the buzzer while in an alarm 3 condition, press and release the reset switch. The ALARM 3 LED will begin to flash indicating the alarm condition has been acknowledged. You cannot de-energize the common alarm 3 relay (relay C) until the gas reading falls below the alarm 3 setpoint.
3. Oxygen alarms are factory set as self-resetting and will automatically clear when the oxygen reading rises above the alarm 3 setpoint.
4. Alarms for all other gas types are factory set as latching. After the gas reading falls below the alarm 3 setpoint, press and release the reset switch to reset the alarm circuit. Resetting the alarm circuit silences the buzzer (if the alarm has not been acknowledged) turns off the ALARM 3 LED, and de-energizes the common alarm 3 relay.

## ***Fail Condition***

This section describes the indications for a fail condition and suggests responses to a fail condition.

### **Fail Condition Indications**

The Beacon 410A senses a fail condition for any of the following:

- the detector head wiring is disconnected or incorrectly connected;
- the display reading is -10% of full scale or lower;
- the Beacon 410A or one of its detector heads is malfunctioning.

When the Beacon 410A senses a fail condition, it alerts you as follows:

- the fail LED turns on;
- the gas reading for the failing channel is replaced by the **FAIL** message;
- the buzzer sounds a steady tone;
- the common fail relay de-energizes.

---

**NOTE:** The fail alarm has a 30 second delay.

---

---

**NOTE:** If you elect to use relays A, B, C, and D as channel fail relays in the Configuration Menu, the appropriate relay de-energizes in a fail condition. Relays A, B, C, and D correspond to channels 1, 2, 3, and 4. See “Viewing and Changing Channel Parameters” on page 50. for a instructions to define channel fail relays.

---

### **Responding to a Fail Condition**

This section suggests responses to a fail condition.

1. To acknowledge the fail condition and silence the buzzer while in a fail condition, press and release the reset switch. The FAIL LED will begin to flash indicating that the fail condition has been acknowledged. The fail circuit is self resetting and cannot be manually reset.
2. Verify that the detector head wiring is correctly and securely connected.
3. See the troubleshooting guide in “Troubleshooting” on page 81.

## ***Low DC Power Condition***

This section describes the audible and visual indications for a low DC power condition and suggests responses to a low DC power condition. This condition only occurs when DC power is used as the primary or a backup power source

### **Low DC Power Condition Indications**

The Beacon 410A senses a DC low power condition when the DC power source is 18.5 volts or less.

---

***WARNING: While in a low power condition, the Beacon 410A is not an active gas monitor.***

---

When the Beacon 410A senses a low DC power condition, it alerts you as follows:

- The FAIL LED turns on.
- The fail relay and all other relays are de-energized.
- The message **LOW POWER S STANDBY** is indicated on the top line of the display and the input voltage is displayed on the bottom line of the display.

---

**NOTE:** The low DC power alarm cannot be cleared using the reset switch.

---

When the DC input voltage increases to 19.0 volts, the low DC power alarm is cleared and the Beacon 410A will begin its warm-up sequence.

### **Responding to a Low DC Power Condition**

- If DC power is the **primary** power source:
  - a. For a *temporary* DC power source, disconnect primary DC power at the Beacon 410A, then connect a 24 VDC battery.
  - b. Determine and correct the cause of primary DC power loss.  
When the DC power source rises above 19.0 volts, the Beacon 410A begins the warm up process.
  - c. Verify that the Beacon 410A enters normal operation after its warm-up sequence.
- If DC power is the **backup** power source:
  - a. If a non-rechargeable battery is used for backup, replace the battery.
  - b. Determine and correct the cause of primary AC power loss. When backup DC or primary AC power is restored, the Beacon 410A begins the warm up process.  
If the Beacon 410A was purchased with the battery charging feature, when AC power is restored, the Beacon 410A charges the backup battery with a charge current of approximately 100 mA until it is fully recharged. Charge time varies depending on the battery size and how much the battery was depleted. Once the battery is fully charged, the Beacon 410A maintains the charge with the 100 mA charge current.
  - c. Verify that the Beacon 410A enters normal operation after its warm-up sequence.

# Chapter 5: Global Menu

---

## Overview

This chapter describes how to view and change Beacon 410A instrument parameters using the Global Menu. The global parameters are the optional strobe's installation setting, the relay normal state setting, the usage setting for relays A, B, C, and D, and the buzzer silence setting. The Global Menu is accessed using the ESCAPE and UP/YES control buttons.

The Global Menu includes a 5-minute timeout feature. If you do not press a control button for 5 minutes, the Beacon 410A automatically returns to normal operation.

---

**NOTE:** If the Beacon 410A returns to normal operation because of a timeout, it enters a warm-up period just as it does when it is first turned on.

If you are installing a new Beacon 410A, it has been set up at the factory. Use the Global Menu only if you want to change the instrument parameter factory settings.

---

---

## Viewing and Changing Global Parameters

---

**WARNING:** *The Beacon 410A is not an active gas monitoring device while in the Global Menu. When you enter the Global Menu, the 4-20 mA output signal will “freeze” at 3.5 mA for each active channel, all relays and alarm LEDs will remain in their current state at the time that you entered the Global Menu, and the alarm buzzer and strobe will turn off if they were activated until you exit the Global Menu. The 4 - 20 mA output signal will not indicate current readings and the relays and alarm LEDs will not resume operating normally until the Beacon 410A is in normal operation again.*

---

---

**NOTE:** You must set the instrument parameters to the desired settings using the Global Menu before making any changes to the channel parameters in the Configuration Menu. Settings in the Global Menu influence what channel parameters appear in the Configuration Menu.

---

1. While in Normal Operation, press and hold the ESCAPE and UP/YES buttons for approximately 5 seconds to enter the Global Menu. Release the buttons when the **You Have Entered the GLOBAL Menu** message appears.

2. Press and release the UP/YES button to continue in the Global Menu to the first global parameter setting screen, the Strobe Installation Screen.

```

S T R O B E   I n s t a l l a t i o n :
      N O   S T R O B E   I N S T A L L E D
U P / D N   t h e n   E N T / E S C
  
```

3. In the parameter screens, use the ENTER button to accept a displayed parameter setting and proceed to the next parameter or the ESCAPE button to backup a screen.
4. If you want to change a displayed parameter setting, use the UP/YES or DOWN/NO button to change the parameter to the desired setting, then press and release the ENTER button to accept the change and proceed to the next screen.
5. Continue through the parameter setting screens changing any parameter settings as needed until the following message appears on the display.

```

S a v e   S e t t i n g s ?
[ Y / N ]
[ E S C A P E ]   t o   b a c k   u p
  
```

6. To save the global parameter settings, press and release the UP/YES button. The screen will indicate that the Beacon 410A is saving the settings for a few seconds then the Beacon 410A will return to normal operation.

If you do not want to save the global parameter settings, press and release the DOWN/NO button. The display will indicate that no settings have been changed for a few seconds then the Beacon 410A will return to normal operation.

Table 7 below lists the global parameters that can be configured in the Global Menu along with the factory set value for each parameter.

**Table 7: Global Menu Parameters**

<b>Global Parameter (Factory-Set Value)</b>	<b>Description</b>
STROBE Installation (Factory setting depends on whether a strobe is supplied with the Beacon 410A.)	If set to <b>STROBE IS INSTALLED</b> , the strobe circuitry is functional and items in the Configuration Menu that apply to the strobe operation become active. If set to <b>NO STROBE INSTALLED</b> , the strobe circuitry does not function and items in the Configuration Menu that apply to the strobe operation do not appear.



**Table 7: Global Menu Parameters (Continued)**

<b>Global Parameter (Factory-Set Value)</b>	<b>Description</b>
<p>NORMAL RELAY STATES (NORM DE-ENERGIZED)</p>	<p>If set to <b>NORM DE-ENERGIZED</b>, the gas alarm relays are de-energized in normal operation and energize when the appropriate alarm circuit is activated. The NO (normally open) relay contacts are open during non-alarm operation and close when the appropriate alarm condition occurs. The NC (normally closed) relay contacts are closed during non-alarm operation and open when the appropriate alarm condition occurs.</p> <p>If set to <b>NORMALLY ENERGIZED</b>, the gas alarm relays are energized in normal operation and de-energize when the appropriate alarm circuit is activated. The NO (normally open) relay contacts are closed during non-alarm operation and open when the appropriate alarm condition occurs. The NC (normally closed) relay contacts are open during non-alarm operation and close when the appropriate alarm condition occurs.</p> <p>The fail relay is factory set as normally energized and is not field adjustable.</p>
<p>RELAYS ABCD used as (COMMON ALARM RELAYS)</p>	<p>If set to <b>COMMON ALARM RELAYS</b>, relays A, B, C, and D are defined as common alarms assigned to the gas alarms as follows:</p> <ul style="list-style-type: none"> <li>• Relay A: Common Alarm 1</li> <li>• Relay B: Common Alarm 2</li> <li>• Relay C: Common Alarm 3</li> <li>• Relay D: Common Any alarm</li> </ul> <p>If set to <b>CHANNEL ALARM RELAYS</b>, relays A, B, C, and D are defined as configurable channel alarm relays assigned to the detection channels as follows:</p> <ul style="list-style-type: none"> <li>• Relay A: Channel 1</li> <li>• Relay B: Channel 2</li> <li>• Relay C: Channel 3</li> <li>• Relay D: Channel 4</li> </ul> <p>Each relay is factory assigned to alarm 3, but this can be changed in the Configuration Menu.</p>
<p>BUZZER SILENCE (CAN SILENCE BUZZER)</p>	<p>If set to <b>CAN SILENCE BUZZER</b>, the buzzer can be silenced by pressing and releasing the reset switch when the Beacon 410A is in a gas alarm condition.</p> <p>If set to <b>CAN'T SILENCE BUZZER</b>, the buzzer cannot be silenced by the reset switch while the Beacon 410A is in a gas alarm condition.</p>

# Chapter 6: Configuration Menu

---

## Overview

This chapter describes how to view and change Beacon 410A channel parameters including alarm point settings and channel relay settings using the Configuration Menu. The Configuration Menu is accessed using the ESCAPE and ENTER control buttons.

The Configuration Menu includes a 5-minute timeout feature. If you do not press a control button for 5 minutes, the Beacon 410A automatically returns to normal operation.

---

**NOTE:** If the Beacon 410A returns to normal operation because of a timeout, it enters a warm-up period just as it does when it is first turned on.

If you are installing a new Beacon 410A, it has been set up at the factory. Use Configuration Mode only if you want to change one or more channel's parameter factory settings. If you want to change a channel's detector type see "Chapter 7: Input Setup Menu" on page 57.

---

---

## Viewing and Changing Channel Parameters

---

**WARNING:** *The Beacon 410A is not an active gas monitoring device while in the Configuration Menu. When you enter the Configuration Menu, the 4-20 mA output signal will "freeze" at 3.5 mA for each active channel, all relays and alarm LEDs will remain in their current state at the time that you entered the Configuration Menu, and the alarm buzzer and strobe will turn off if they were activated until you exit the Configuration Menu. The 4 - 20 mA output signal will not indicate current readings and the relays and alarm LEDs will not resume operating normally until the Beacon 410A is in normal operation again.*

---

1. While in normal operation, simultaneously press and hold the ESCAPE and ENTER buttons for approximately 5 seconds to enter the Configuration Menu. Release the buttons when the **You Have Entered the CONFIGURATION Menu** message appears on the display.
2. Press and release the UP/YES button to continue in the Configuration Menu to the Select Channel Screen.

```
S e l e c t   C h a n n e l
                1
U P / D N   t h e n   E N T / E S C
```

- Use the UP/YES or DOWN/NO buttons to select the channel whose parameters you want to view and/or update, then press and release the ENTER button. The first channel parameter screen appears and it allows you to select whether the channel is set to **ACTIVE**, **STANDBY**, or **NOT USED**.
- Press and release the UP /YES or DOWN/NO button until the setting you want to select appears, then press and release the ENTER button to save it. The next channel parameter screen appears.

---

**NOTE:** If you selected STANDBY or NOT USED, the display will ask you if you still want to review the channel settings. If yes, press and release the UP/YES button and continue with Step 5. If no, press and release the DOWN/NO button and proceed to Step 9.

---

---

**NOTE:** Use the ESCAPE button to go backwards in the menu.

---

- In the parameter screens, use the ENTER button to accept a displayed parameter setting and proceed to the next parameter or the ESCAPE button to backup a screen.
- If you want to change a displayed parameter setting, use the UP/YES or DOWN/NO button to change the parameter to the desired setting, then press and release the ENTER button to accept the change and proceed to the next screen.
- Continue through the parameter setting screens changing any parameter settings as needed until the following message appears on the display.

```
S a v e   S e t t i n g s ?  
[ Y / N ]  
[ E S C A P E ]   t o   b a c k   u p
```

- To save the channel parameter settings, press and release the UP /YES button. The screen will indicate that the Beacon 410A is saving the settings for a few seconds.

If you do not want to save the channel parameter settings, press and release the DOWN/NO button. The display will indicate that no settings have been changed for a few seconds and the channel parameters will return to their original settings.

- The following screen will appear asking if you want to configure more channels.

```
D o   Y o u   W a n t   T o  
D o   M o r e   C h a n n e l s ?  
[ Y / N ]
```

If yes, press and release the UP/YES button to return to the Select Channel Screen. Begin at instruction Step 3 above to configure another channel.

If no, then press the DOWN /NO button to return to normal operation.

Table 8 below lists the channel parameters that can be viewed and updated in the Configuration Menu along with the factory set value for each parameter.

**Table 8: Configuration Menu Parameters**

<b>Channel Parameter (Factory-Set Value)</b>	<b>Description</b>
Channel Status (Factory setting depends on whether a detector is supplied for a channel.)	<p>If set to <b>ACTIVE</b>, the channel will be fully functional.</p> <p>If set to <b>STANDBY</b>, the channel's gas name and reading will be replaced by <b>STANDBY</b> on the display. The channel's relays will be fixed in their non-alarm state and the 4 - 20 mA output for the channel will be fixed at 3.5 mA. This setting is typically used when maintenance is being performed on a channel.</p> <p>If set to <b>NOT USED</b>, the channel is not functional and the gas name and reading field for that channel indicates <b>NOT USED</b>. All the channel's relays are de-energized and the 4 - 20 mA output is fixed at about 0.7 mA.</p>
Strobe Setting (USE w/ Alarms Only)	<p>If set to <b>USE w/ Alarms Only</b>, the strobe will activate when the appropriate gas alarm condition occurs as defined in the alarm strobe settings (see below) in the Configuration Menu. It will not operate when a fail alarm occurs.</p> <p>If set to <b>USE w/ Alarms and Fail</b>, the strobe will activate when the appropriate gas alarm condition occurs and when a fail alarm occurs.</p> <p>If set to <b>DON'T USE</b>, the none of the strobe alarm settings appear in the Configuration menu and the strobe circuit does not function.</p> <p><i><b>NOTE:</b> This parameter appears only if the <b>STROBE Installation</b> parameter in the Global Menu is set to <b>Strobe Installed</b>.</i></p>
Alarm-1 Level (See the Beacon 410A Detector Head Specification sheet for the detector head installed on this channel.)	The gas reading at which an alarm 1 condition occurs and the Beacon 410A activates the alarm 1 circuit for this channel.
Alarm-1 Inc/Dec (DECREASING for oxygen, INCREASING for all other channel types)	Indicates if the alarm 1 circuit is activated by gas reading <b>INCREASING</b> or <b>DECREASING</b> to the alarm 1 level.
Alarm-1 Latching (SELF-RESETTING for oxygen, LATCHING for all other channel types)	<p>If set as <b>LATCHING</b>, you must press the RESET button to reset the alarm 1 circuit after the alarm 1 condition passes.</p> <p>If set as <b>SELF-RESETTING</b>, the Beacon 410A automatically resets the alarm 1 circuit after the alarm 1 condition passes.</p>
Alarm-1 ON Delay (1 Second)	The amount of time the Beacon 410A delays activation of the alarm 1 circuit after the gas reading reaches the alarm 1 setpoint.

**Table 8: Configuration Menu Parameters (Continued)**

<b>Channel Parameter (Factory-Set Value)</b>	<b>Description</b>
ALARM-1 OFF DELAY (0 Seconds)	<p>The amount of time the Beacon 410A delays resetting the alarm 1 circuit after the alarm 1 condition passes.</p> <p><i>NOTE: This parameter appears only if the <b>ALARM-1 Latching</b> parameter is set to <b>SELF-RESETTING</b>.</i></p>
ALM-1 STROBE Setting (NonResettable STROBE)	<p>If set to <b>Resettable STROBE</b>, the strobe can be turned off with the Reset Switch while an alarm 1 condition still exists.</p> <p>If set to <b>NonResettable STROBE</b>, the strobe cannot be turned off with the Reset Switch while an alarm 1 condition still exists.</p> <p>If set to <b>NO STROBE</b>, the strobe will not activate due to an alarm 1 condition.</p> <p><i>NOTE: This parameter appears only if the <b>STROBE Installation</b> parameter in the Global Menu is set to Strobe Installed and the Strobe Setting parameter in the Configuration Menu is set to <b>USE w/ Alarms Only</b> or <b>USE w/ Alarms and Fail</b>.</i></p>
Alarm-2 Level (See the Beacon 410A Detector Head Specification sheet for the detector head installed on this channel.)	<p>The gas reading at which an alarm 2 condition occurs and the Beacon 410A activates the alarm 2 circuit for this channel.</p>
Alarm-2 Inc/Dec (INCREASING)	<p>Indicates if the alarm 2 condition is activated by gas readings <b>INCREASING</b> or <b>DECREASING</b> to the alarm 2 level.</p>
Alarm-2 Latching (SELF-RESETTING for oxygen, LATCHING for all other channel types)	<p>If set as <b>LATCHING</b>, you must press the RESET button to reset the alarm 2 circuit after the alarm 2 condition passes.</p> <p>If set as <b>SELF-RESETTING</b>, the Beacon 410A automatically resets the alarm 2 circuit after the alarm 2 condition passes.</p>
Alarm-2 ON Delay (120 Seconds for oxygen, 1 Second for all other chan- nel types)	<p>The amount of time the Beacon 410A delays activation of the alarm 2 circuit after the gas reading reaches the alarm 2 setpoint.</p>
Alarm-2 OFF DELAY (0 Seconds)	<p>The amount of time the Beacon 410A delays resetting the alarm 2 circuit after the alarm 2 condition passes.</p> <p><i>NOTE: This parameter appears only if the <b>ALARM-2 Latching</b> parameter is set to <b>SELF-RESETTING</b>.</i></p>

**Table 8: Configuration Menu Parameters (Continued)**

<b>Channel Parameter (Factory-Set Value)</b>	<b>Description</b>
ALM-2 STROBE Setting (NonResettable STROBE)	<p>If set to <b>Resettable STROBE</b>, the strobe can be turned off with the Reset Switch while an alarm 2 condition still exists.</p> <p>If set to <b>NonResettable STROBE</b>, the strobe cannot be turned off with the Reset Switch while an alarm 2 condition still exists.</p> <p>If set to <b>NO STROBE</b>, the strobe will not activate due to an alarm 2 condition.</p> <p><i><b>NOTE:</b> This parameter appears only if the <b>STROBE</b> Installation parameter in the Global Menu is set to Strobe Installed and the Strobe Setting parameter in the Configuration Mode is set to <b>USE w/ Alarms Only</b> or <b>USE w/ Alarms and Fail</b>.</i></p>
Alarm-3 Level (See the Beacon 410A Detector Head Specification sheet for the detector head installed on this channel.)	The gas reading at which an alarm 3 condition occurs and the Beacon 410A activates the alarm 3 circuit for this channel.
Alarm-3 Inc/Dec (DECREASING for oxygen, INCREASING for all other channel types)	Indicates if the alarm 3 circuit is activated by gas readings <b>INCREASING</b> or <b>DECREASING</b> to the alarm 3 level.
Alarm-3 Latching (SELF-RESETTING for oxygen, LATCHING for all other channel types)	<p>If set as <b>LATCHING</b>, you must press the RESET button to reset the alarm 3 circuit after the alarm 3 condition passes.</p> <p>If set as <b>SELF-RESETTING</b>, the Beacon 410A automatically resets the alarm 3 circuit after the alarm 3 condition passes.</p>
Alarm-3 ON Delay (1 Second)	The amount of time the Beacon 410A delays activation of the alarm 3 circuit after the gas reading reaches the alarm 3 setpoint.
Alarm-3 OFF DELAY (0 Seconds)	<p>The amount of time the Beacon 410A delays resetting the alarm 3 circuit after the alarm 3 condition passes.</p> <p><i><b>NOTE:</b> This parameter appears only if the <b>ALARM-3 Latching</b> parameter is set to <b>SELF-RESETTING</b>.</i></p>

**Table 8: Configuration Menu Parameters (Continued)**

<b>Channel Parameter (Factory-Set Value)</b>	<b>Description</b>
ALM-3 STROBE Setting (NonResettable STROBE)	<p>If set to <b>Resettable STROBE</b>, the strobe can be turned off with the Reset Switch while an alarm 3 condition still exists.</p> <p>If set to <b>NonResettable STROBE</b>, the strobe cannot be turned off with the Reset Switch while an alarm 3 condition still exists.</p> <p>If set to <b>NO STROBE</b>, the strobe will not activate due to an alarm 3 condition.</p> <p><i><b>NOTE:</b> This parameter appears only if the <b>STROBE Installation</b> parameter in the Global Menu is set to Strobe Installed and the Strobe Setting parameter in the Configuration Mode is set to <b>USE w/ Alarms Only</b> or <b>USE w/ Alarms and Fail</b>.</i></p>
Relay-1 Assignment (ALARM-1)	<p>The alarm condition that activates relay 1. It can be set for activation by the following alarm conditions:</p> <ul style="list-style-type: none"> <li>• ALARM-1</li> <li>• ALARM-2</li> <li>• ALARM-3</li> <li>• ALARMS 1 or 2</li> <li>• ALARMS 1 or 3</li> <li>• ALARMS 2 or 3</li> <li>• ALARMS 1, 2, or 3</li> <li>• Use As Channel FAIL (If you choose this setting, the relay is normally energized)</li> </ul>
Relay-2 Assignment (ALARM-2)	<p>The alarm condition that activates relay 2. It can be set for activation by the following alarm conditions:</p> <ul style="list-style-type: none"> <li>• ALARM-1</li> <li>• ALARM-2</li> <li>• ALARM-3</li> <li>• ALARMS 1 or 2</li> <li>• ALARMS 1 or 3</li> <li>• ALARMS 2 or 3</li> <li>• ALARMS 1, 2, or 3</li> <li>• Use As Channel FAIL (If you choose this setting, the relay is normally energized)</li> </ul>

**Table 8: Configuration Menu Parameters (Continued)**

<b>Channel Parameter (Factory-Set Value)</b>	<b>Description</b>
<p>Relay-X Assignment (ALARM-3)</p> <p><i><b>NOTE:</b> Relay-X will be either Relay-A for channel 1, Relay-B for channel 2, Relay-C for channel 3, or Relay-D for channel 4.</i></p>	<p>The alarm condition that activates relay X. It can be set for activation by the following alarm conditions:</p> <ul style="list-style-type: none"> <li>• ALARM-1</li> <li>• ALARM-2</li> <li>• ALARM-3</li> <li>• ALARMS 1 or 2</li> <li>• ALARMS 1 or 3</li> <li>• ALARMS 2 or 3</li> <li>• ALARMS 1, 2, or 3</li> <li>• Use As Channel FAIL (If you choose this setting, the relay is normally energized)</li> </ul> <p><i><b>NOTE:</b> This parameter appears only if the <b>RELAYS ABCD</b> used as parameter in the Global Menu is set to <b>CHANNEL ALARM RELAYS</b>.</i></p>
<p>NOISE FILTER (5 seconds)</p>	<p>The noise filter feature helps “smooth out” jumpy or noisy signals from the detector head. The filter setting indicates the number of seconds over which the displayed reading is being averaged. You can set the noise filter from 1 second to 10 seconds.</p> <p>A setting of 10 seconds produces the greatest amount of smoothing, but causes the displayed gas reading to respond more slowly to changes in gas concentrations.</p> <p>A setting of 1 second gives the fastest gas reading response to a change in gas concentration, but gives the least amount of smoothing.</p>
<p>Deadband (0.0% of <b>Full Scale</b> in terms of the channel’s units for carbon dioxide channel types; 0.5% <b>oxygen</b> for oxygen channels; 2.0% of <b>Full Scale</b> in terms of the channel’s units for all other channel types.)</p>	<p>The deadband setting defines the first gas concentration that will be displayed when the gas reading increases or decreases from the normal fresh air concentration (20.9 for oxygen and 0 for all other channel types). This feature helps prevent “jumpy” readings near the normal fresh air reading.</p> <p>For example, if the deadband setting is <b>2% LEL</b> for a combustible channel whose range is 0 - 100% LEL, the Beacon 410A will display a reading of 0% LEL for gas readings from -1% LEL to 1% LEL.</p> <p><i><b>NOTE:</b> The MPS<sup>TM</sup> sensor has a built-in deadband of 3% LEL for methane (CH<sub>4</sub>) and 5% LEL for all other gases. Even if the Beacon 410A’s deadband is set to 2% LEL for an MPS channel, a reading will not be displayed until it has exceeded the MPS sensor’s internal deadband.</i></p>



# Chapter 7: Input Setup Menu

---

## Overview

This chapter describes how to use the Input Setup Menu to select each channel's detector head input type and the gas setup. The detector head input type determines whether a direct connect type or a 4 - 20 mA type of detector head will be used and the gas setup determines the target gas, detection units, and the detection range full scale. The Input Setup Menu is accessed using the ENTER control button when powering up the Beacon 410A.

The Input Setup Menu includes a 5-minute timeout feature. If you do not press a button for 5 minutes, the Beacon 410A automatically returns to normal operation.

---

**NOTE:** The Beacon 410A will begin its warm-up sequence when it exits the Input Setup Menu before it enters normal operation whether because of a program timeout or because you are done with input setup and are exiting manually.

---

---

## Selecting the Detector Head Input Type and Gas Setup

---

**NOTE:** The Beacon 410A must be turned off before you can enter the Input Setup Menu. If your Beacon 410A is already installed and operating, make sure that turning the Beacon 410A off will not cause unwanted alarms before continuing.

---

1. While the Beacon 410A is off, press and hold the ENTER button, then turn on the Beacon 410A with the ON/OFF switch.
2. Continue to press the ENTER button while the Beacon 410A turns on and the display shows **RKI Instruments Beacon 410A**. Release the ENTER button when the following screen appears on the display.

```
Y o u   H a v e   E n t e r e d   T h e
      I N P U T   S E T U P   M e n u
C o n t i n u e ?   [ Y / N ]
```

- If you want to exit the Input Menu, press and release the DOWN/NO button. The Beacon 410A will exit the Input Menu and begin the warm-up sequence.

If you want to continue in the Input Menu, press and release the UP/YES button. The Select Channel(s) screen will appear.

```

S e l e c t   C h a n n e l
                1
U P / D N   t h e n   E N T / E S C
  
```

- The setup that you perform will apply to all the channels that you select. Select the channel or channels you want to setup by using the UP/YES or DOWN/NO buttons to scroll through the choices and then press and release the ENTER button to accept the selection. The INPUT Type screen will appear. In the example below, channels 1 and 2 have been selected for setup.

```

C H A N N E L ( S ) :   1 , 2
I N P U T   T y p e
  4 - 2 0 m A   T R A N S M I T T E R
U P / D N   t h e n   E N T / E S C
  
```

- Use the UP/YES or DOWN/NO button to scroll through the choices of input types. Table 9 below lists the choices of input type for the Beacon 410A.

**Table 9: Beacon 410A Detector Head Input Types**

<b>Detector Head Input Type</b>	<b>Description</b>
4-20 mA TRANSMITTER	A <b>4-20 mA TRANSMITTER</b> detector head is connected to the Beacon 410A with 2 or 3 wires, depending on the detector head model, using the AMP +, S, and - terminals on the detector/transmitter terminal strips. All calibration adjustments are made at the detector head.
PREAMP DIRECT	A <b>PREAMP DIRECT</b> detector head is connected to the Beacon 410A with 2 wires using the AMP + and S terminals on the detector/transmitter terminal strips. All calibration adjustments are made at the Beacon 410A.
OXYGEN DIRECT (25%)	An <b>OXYGEN DIRECT</b> detector head is an oxygen detector head in which the oxygen detector is wired to the Beacon 410A with 2 wires using the OXY W (white) and G (green) terminals from on the detector/transmitter terminal strips. All calibration adjustments are made at the Beacon 410A.

**Table 9: Beacon 410A Detector Head Input Types**

Detector Head Input Type	Description
RWGB DIRECT (LEL)	An <b>RWGB DIRECT (LEL)</b> detector head is detector head in which the detector is wired to the Beacon 410A with 4 wires using the LEL R (red), W (white), G (green) and B (black) terminals on the detector/transmitter terminal strips. All calibration adjustments are made at the Beacon 410A. This type of detector head is typically a combustible gas LEL detector head, but may be another type such as a CO <sub>2</sub> detector.

6. When the desired detector head input type is shown on the display, press and release the ENTER button to accept it. The PreDefined Gas Setup screen will appear.

```

CHANNEL ( S ) : 1 , 2
PreDefined Gas Setup
METHANE 100 %LEL
UP / DN then ENT / ESC
    
```

7. Use UP/YES or DOWN/NO button to scroll through the gas setup choices. There are several choices whose gas name, full scale, and detection units are predefined. For these choices, the gas name, full scale, and detection units are displayed. There is also one choice named **CUSTOM** that allows you to enter the gas name, full scale, and detection units.
8. When the desired setup choice is shown on the display, press and release the ENTER button to accept it.

If you selected a predefined gas setup, the Save Settings? screen will appear. Proceed to Step 10.

If you selected the **CUSTOM** choice, the Gas Name screen will appear. Proceed to Step 9.

---

**NOTE:** The **CUSTOM** choice is especially useful if you are connecting a 4 - 20 mA transmitter to the Beacon 410A that is not a gas detector, such as a temperature or pressure transducer.

---

9. If you selected the **CUSTOM** choice, perform the following steps to define the gas name, detection units, and full scale.
- With the Gas Name screen displayed, use the UP/YES or DOWN/NO button to scroll through the gas name choices. The list includes one choice called **Spell It**. This choice allows you to enter a name that is not on the list.
  - When the desired choice is displayed, press and release the ENTER button.
  - If you selected a gas name, the Gas Units screen appears.
    - If you selected **Spell It**, a screen appears that indicates **Currently, Gas Name Is Spelled As:**. If the displayed name is OK, press and release the UP/YES button and the Gas Units screen appears. If you want to change the displayed name, perform the following steps to enter the desired gas name.

- Press and release the DOWN/NO button. The top display line indicates **Spell Out Gas Name**.
  - An eight character wide text field appears on the left side of the third display line enclosed by single quotes. A vertical cursor appears below the far left text position indicating that this character position can be edited. Use the UP/YES or DOWN/NO button to scroll through the character choices. When the desired character is displayed, press and release the ENTER button to save that character and move to the next position. Use the ESCAPE button to return to a previous character if you want to change it.
  - Repeat the previous step until all the text positions are saved. After the last character is saved, the Units screen appears.
  - Use the UP/YES or DOWN/NO button to scroll through the units choices. When the desired units are displayed, press and release the ENTER button. The Full Scale Readout screen appears.
  - USE the UP/YES or DOWN/NO button to scroll through the available choices for the full scale setting. When the desired full scale setting is displayed, press and release the ENTER button. The Save Settings? screen appears.
10. If you want to save the setup, press and release the UP/YES button. The display will indicate that the settings have been saved before asking if you want to setup more channels.

---

**NOTE:** If you defined a custom setup by selecting the **CUSTOM** choice in the PreDefined Gas Setup screen, you will be required to review the channel parameters from the Configuration Menu. See “Viewing and Changing Channel Parameters” on page 50 for a description of the channel parameters.

---

If you do not want to save the setup, press and release the DOWN/NO button. You will return to the Select Channel(s) screen. Follow the instructions from Step 4 above.

11. If you want to setup more channels, press and release the UP/YES button. You will return to the Select Channel(s) screen. Follow the instructions from Step 4 above.

If you do not want to setup more channels, press and release the DOWN/NO button and the Beacon 410A will exit the Input Setup Menu and begin its warm-up sequence.

# Chapter 8: Calibration Mode

---

## Overview

This chapter describes how to calibrate the Beacon 410A's active channels using Calibration Mode. In Calibration Mode, you can:

- Set the calibration timeout.
- Perform a fresh air adjust on selected channels.
- Perform a gas adjust on selected channels.

---

**NOTE:** A direct connect O<sub>2</sub> channel must be calibrated with 0 - 16% O<sub>2</sub>. All other direct connect channels must be calibrated with a gas concentration between 10% and 100% of the channel's full scale value (ie. a 0 - 300 ppm CO channel must be calibrated with a CO concentration between 30 and 300 ppm).

---

- View Max Spans.

Table 10 below briefly describes the four operations that can be performed in Calibration Mode. A more detailed description of each operation is given later in this chapter.

**Table 10: Calibration Mode Functions**

Operation	Description
SET CAL TIMEOUT	The calibration timeout sets the amount of time after the last button push while in Calibration Mode that the Beacon 410A will wait before automatically returning to normal operation.
PERFORM AIR ADJUST	This operation allows you to set the fresh air reading of the selected channel(s) to zero (20.9% for an oxygen channel).
PERFORM GAS ADJUST	This operation allows you to set the response reading of the selected channels with calibration gas.
VIEW MAX SPANS	This operation gives a measure of how much gas response adjustment remains on a direct connect type channel by allowing you to view the maximum possible adjustment on gas during the most recent calibration for each channel.

---

# Calibration Frequency

Although there is no particular calibration frequency that is correct for all applications, a calibration frequency of every 3 to 6 months is adequate for most Beacon 410A applications. Unless experience in a particular application dictates otherwise, RKI Instruments, Inc. recommends a calibration frequency of every 3 months.

If an application is not very demanding, for example detection in a clean, temperature controlled environment where a combustible or toxic gas is not normally present, and calibration adjustments are minimal at calibration, then a calibration frequency of every 6 months may be adequate.

If an application is very demanding, for example if a combustible or toxic gas is present often and in significant concentrations or the environment is not well controlled, then more frequent calibration than every 3 months may be necessary. For combustible gas detection using catalytic combustion type detectors, if potential catalyst poisons are known or likely to be present, more frequent calibration than every 3 months will be necessary.

---

# Detector Head Types

The Beacon 410A can support both direct connect (internal amp) and 4-20 mA transmitter (remote amp) detector heads. Since the Beacon 410A can support both types of detector heads, there are three possible detector head combinations when calibrating the active channels:

- Direct connect detector heads only.  
If all the active channels are direct connect detector heads, then all calibration adjustments are made at the Beacon 410A after calibration gas is applied to the detectors.
- 4-20 mA transmitter detector heads only.  
If all the active channels are 4 - 20 mA transmitter detector heads, then all calibration adjustments are made at the detector head when calibration gas is applied to the detectors.
- Direct connect and 4-20 mA transmitter detector heads.  
If both direct connect and 4-20 mA transmitter detector heads are installed, then calibration adjustments must be made at the Beacon 410A for the direct connect detector heads after applying gas to the detectors, and at the detector heads when gas is applied for the 4-20 mA transmitter detector heads.

---

# Calibration Gas Response Memory Feature

When a direct connect detector head is installed, the Beacon 410A has the capability to “remember” the detector’s response to the calibration gas after the gas is removed from the detector during the fresh air or span (zero for an oxygen detector) adjustment procedure. This feature enables one person to perform calibration if the detector heads are mounted remotely from the Beacon 410A. When zero air is applied to a detector head during a fresh air adjustment in Calibration Mode, the Beacon 410A will freeze the display reading at the lowest (highest for an oxygen detector head) response and the Beacon 410A will continue to display this reading and retain it in its memory until the fresh air adjustment procedure is completed. When calibration gas is applied to a detector head during a span (zero for an oxygen detector) adjustment in Calibration Mode, the Beacon 410A will freeze the display reading at the highest (lowest for an oxygen detector) response to the calibration gas. The calibration gas can then be removed and the Beacon 410A will continue to display this reading and retain it in its memory until the span (zero for an oxygen detector) adjustment procedure is completed.

---

## Entering Calibration Mode

---

***WARNING: The Beacon 410A is not an active gas monitoring device during the calibration procedure. When you enter Calibration Mode, the 4-20 mA output signal will “freeze” at 3.5 mA for each active channel, all relays and alarm LEDs will remain in their current state at the time that you entered Calibration Mode, and the alarm buzzer and strobe will turn off if they were activated until you exit Calibration Mode. The 4 - 20 mA output signal will not indicate current readings and the relays and alarm LEDs will not resume operating normally until the Beacon 410A is in normal operation again.***

---

1. Assemble the calibration kit(s). See the instruction manual for each detector head for procedures specific to that detector head.
2. While in normal operation, simultaneously press and hold the ENTER and UP/YES buttons for approximately 3 seconds to enter Calibration Mode. Release the buttons when the **You Have Entered The CALIBRATION Mode...** message displays and asks if you want to continue in the Calibration Menu.

3. If you want to exit Calibration Mode, press and release the DOWN/NO button. The Beacon 410A will return to normal operation.

If you want to continue in Calibration Mode, press and release the UP/YES button to continue and display the Select Operation screen. The SET CAL TIMEOUT item will be displayed.

```
S e l e c t   O p e r a t i o n
      S E T   C A L   T I M E O U T
U P / D N   t h e n   E N T / E S C
```

The next two sections describe how to set the calibration timeout and calibrate the Beacon 410A's detector heads.

---

## Calibration Timeout Setting

The calibration timeout setting defines the amount of time after the last button push that the Beacon 410A will remain in Calibration Mode before automatically exiting Calibration Mode and entering normal operation. If the Beacon 410A exits Calibration Mode because of the automatic timeout, it will begin its warm-up sequence just as it does when it is turned on.

To view or change the calibration timeout setting, do the following:

1. Navigate to the Select Operation Screen as described in the previous section.
2. With **SET CAL TIMEOUT** displayed, press and release the ENTER button. The Calibration Timeout Screen appears.

```
C a l i b r a t i o n   T i m e o u t
      1 5   m i n u t e s
U P / D N   t h e n   E N T / E S C
```

3. Use the UP/YES or DOWN/NO button to adjust the calibration timeout to the desired setting. The calibration timeout can be set from 5 minutes to 240 minutes (4 hours) in 5 minute increments. The factory set calibration timeout is 15 minutes.
4. If you want to save the displayed calibration timeout setting, press and release the ENTER button. The display will indicate that the setting has been saved before returning to the Select Operation Screen.

If you do not want to save the displayed calibration timeout setting, press and release the ESCAPE button. The display will indicate that nothing has changed before returning to the Select Operation Screen.

5. Press and release the ESCAPE button. The **You Have Entered The CALIBRATION Mode...** message displays and asks if you want to continue in Calibration Mode.
6. Press the DOWN/NO button to exit Calibration Mode and enter normal operation.



---

# Performing a Calibration

It is possible to perform only an air adjustment or a gas response adjustment since it is not always necessary to perform a complete calibration. For example, during startup, it is typically only necessary to perform an air adjustment since the Beacon 410A is shipped with all the factory setup channels calibrated. However, for a complete calibration, you must perform both a fresh air adjustment and a gas response adjustment.

## ***Performing a Fresh Air Adjustment***

Performing a fresh air adjustment sets the gas reading in fresh air for the selected channels to zero for all channel types except oxygen. An oxygen channel is set to 20.9% in fresh air. If you suspect that the environment at a detector head location is not a fresh air environment, an environment of normal oxygen content, 20.9%, and free of combustible or toxic gasses, you will need to apply zero-emission air, also known as zero air, to the detector when making the fresh air adjustment. See the operator's manual for each detector head that you are air adjusting for instructions specific to that detector head.

To perform a fresh air adjustment for the selected channels, do the following:

1. Navigate to the Select Operation Screen as described in "Entering Calibration Mode" on page 63.
2. Use the UP/YES or DOWN/NO button to display **PERFORM AIR ADJUST** on the Select Operation Screen.
3. Press and release the ENTER button. The Select Channel(s) screen appears.

S	e	l	e	c	t		C	h	a	n	n	e	l	(	s	)			
F	o	r		F	R	E	S	H		A	I	R		A	d	j	u	s	t
											1								
U	P	/	D	N		t	h	e	n		E	N	T	/	E	S	C		

4. Use the UP/YES or DOWN/NO button to scroll through the channel combination choices and select the channel or channels that you will air adjust.

- Press and release the ENTER button to accept the displayed choice and continue with the air adjustment. The display will alternate between the top two screens shown below. In the example below, channels 1, 2, 3, and 4 have been selected for an air adjust.

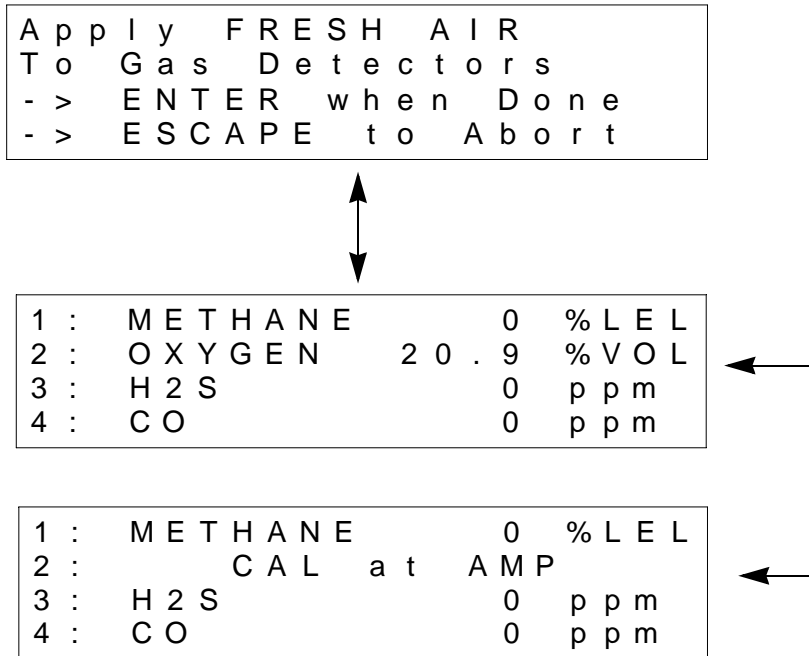

If any of the displayed channels is a 4 - 20 mA type detector head, the gas name and concentration will alternate with **CAL at AMP**. In the example above, channel 2 is a 4 - 20 mA type channel.

- Verify that the detector heads are in a fresh air environment. If you cannot confirm a fresh air environment, use a zero air cylinder to introduce fresh-air to each detector when adjusting the fresh air reading below. If you are air adjusting both 4 - 20 mA and direct connect types of detector heads, air adjust the 4 - 20 mA type detector heads at the detector heads first, then apply zero air to and air adjust the direct connect type detector heads to avoid exiting the air adjustment screens prematurely before you have adjusted the 4 - 20 mA type detector heads.
- For a 4 - 20 mA type detector head, adjust the detector head's fresh air reading (sometimes referred to as the zero reading for non-oxygen detector heads) at the detector head. See the detector head operator's manual for instructions on how to adjust the fresh air reading.
- If you are only air adjusting 4 - 20 mA type detector heads, press the ENTER button when you are done to return to the Select Operation Screen. Proceed to Step 10.

If you are air adjusting both 4 - 20 mA type detector heads and direct connect detector heads, proceed to Step 9.

9. For direct connect type detector heads, if the detector heads are in a fresh air environment, press and release the ENTER button. The Beacon 410A will perform a fresh air adjustment and the display will indicate **AIR ADJUST PASSED** for each direct connect type detector head if the air adjust is successful. If the air adjust was not successful for any channel, the display will indicate **AIR ADJUST FAILED** for that channel. The Beacon 410A will then return to the Select Operation screen.

If you suspect the detector area is not a fresh air environment, apply zero air to each selected detector before pressing the ENTER button to perform the fresh air adjustment. See each detector head's operator's manual for instructions to apply zero air to each detector. The Beacon 410A will freeze the display reading at the lowest level reached while applying zero air (highest level for an oxygen detector head). After applying zero air for the required amount of time, usually two minutes, remove the zero air source from the detector. Press and release the ENTER button at the Beacon 410A. The Beacon 410A will perform a fresh air adjustment and the display will indicate **AIR ADJUST PASSED** for each direct connect type detector head if the air adjust is successful. The Beacon 410A will then return to the Select Operation screen.

10. If you want to perform a gas adjustment to complete the calibration, proceed to the next section, "Performing a Gas Adjustment".

If you do not want to perform a gas adjustment, press and release the ESCAPE button to return to the initial screen that says **You Have Entered CALIBRATION Mode...** and then press and release the DOWN/NO button to exit Calibration Mode and return to normal operation.

## ***Performing a Gas Adjustment***

Performing a gas adjustment sets the response level to calibration gas for the selected channels. This is also known as a span adjustment. See the operator's manual for each detector head that you are gas adjusting for instructions specific to that detector head.

To perform a gas adjustment for the selected channels, do the following:

1. Navigate to the Select Operation Screen as described in "Entering Calibration Mode" on page 63 or proceed to the next step if you just completed an air adjustment and are at the Select Operation Screen.
2. Use the UP/YES or DOWN/NO button to display **PERFORM GAS ADJUST** on the Select Operation Screen.
3. Press and release the ENTER button. The Select Channel(s) screen appears.

S	e	l	e	c	t		C	h	a	n	n	e	l	(	s	)	
F	o	r		C	A	L		G	A	S		A	d	j	u	s	t
											1						
U	P	/	D	N		t	h	e	n		E	N	T	/	E	S	C

4. Use the UP/YES or DOWN/NO button to scroll through the channel combination choices and select the channel or channels that you will air adjust. In the gas adjustment example below, channels 1, 2, 3, and 4 have been selected.

- Press and release the ENTER button to accept the displayed choice and continue with the gas adjustment. The display will show the calibration gas concentration that the Beacon 410A expects you to use for the gas adjustment for the first selected direct connect type channel.

```

C H A N N E L   1
C A L   G A S   T o   B e   U s e d
M E T H A N E           5 0   % L E L
U P / D N   t h e n   E N T / E S C
  
```

- Use the UP/YES and DOWN;/NO buttons to make the displayed concentration match the calibration gas concentration, then press and release the ENTER button to accept it. The display will show the expected calibration gas concentration for the next selected direct connect type channel.

---

**NOTE:** An O<sub>2</sub> channel must be calibrated with 0 - 16% O<sub>2</sub>. All other channels must be calibrated with a gas concentration between 10% and 100% of the channel's full scale value (ie. a 0 - 300 ppm CO channel must be calibrated with a CO concentration between 30 and 300 ppm).

---

- Repeat Step 6 for each selected direct connect channel. When the last selected direct connect channel's calibration gas concentration has been accepted, the top two screens shown below will alternate.

```

A p p l y   C A L   G A S
T o   G a s   D e t e c t o r s
- >   E N T E R   w h e n   D o n e
- >   E S C A P E   t o   A b o r t
  
```

```

1 :   M E T H A N E           0   % L E L
2 :   O X Y G E N           2 0 . 9   % V O L
3 :   H 2 S                   0   p p m
4 :   C O                       0   p p m
  
```

```

1 :   M E T H A N E           0   % L E L
2 :           C A L   a t   A M P
3 :   H 2 S                   0   p p m
4 :   C O                       0   p p m
  
```

If any of the displayed channels is a 4 - 20 mA type detector head, the gas name and concentration will alternate with **CAL at AMP**. In the example above, channel 2 is a 4 - 20 mA type channel

8. For a 4 - 20 mA type detector head, adjust the detector head's gas response at the detector head. See the detector head operator's manual for instructions on how to adjust the gas response reading. This is sometimes referred to as adjusting the span (or zero for an oxygen channel).
9. If you are only gas adjusting 4 - 20 mA type detector heads, press the ENTER button when you are done to return to the Select Operation Screen. Proceed to Step 12.  
  
If you are air adjusting both 4 - 20 mA type detector heads and direct connect detector heads, proceed to Step 10.
10. For direct connect type detector heads, apply calibration gas to each selected detector. See each detector head's operator's manual for instructions on how to apply gas to each detector.  
  
When calibration gas is applied to a detector, the Beacon 410A will freeze the display gas reading at the highest level reached while the gas was applied (lowest for an oxygen detector head). After applying calibration gas for the required amount of time, usually two minutes, remove the gas from the detector. The Beacon 410A will continue to display the maximum gas response (lowest for an oxygen detector head) on the display and retain the response level in its memory.
11. After you have applied gas to each direct connect detector head, press and release the ENTER button. The Beacon 410A will perform a gas adjustment on the direct connect type channels and indicate **GAS ADJUST PASSED** for each direct connect type channel. If the gas adjust was not successful for any channel, the display will indicate **GAS ADJUST FAILED** for that channel. The Beacon 410A will then return to the Select Operation screen.
12. Press and release the ESCAPE button to return to the initial Calibration Mode Screen that says **You Have Entered the CALIBRATION Menu...**
13. Remove the calibration gas from the detector(s).

---

**NOTE:** Allow time for the calibration gas to clear from the detector.

---

14. Press and release the DOWN/NO button to exit Calibration Mode and return to normal operation.
15. The display for the calibrated channel(s) will alternate between the gas reading and **REMOVE CAL GAS** for 1 minute. During this 1 minute period, the relays will remain in their non-alarm state to avoid unwanted alarms while the calibration gas clears from the detector. At the end of the 1 minute period, the **REMOVE CAL GAS** message will stop appearing and the Beacon 410A will return to normal operation.

---

## Viewing Maximum Spans

This operation allows you to see how much gas response adjustment remains on direct connect type channels after a calibration is performed. This is a useful gauge for whether or not a sensor is nearing the end of its life. When you enter the VIEW MAX SPANS screen, the Beacon 410A displays the maximum possible adjustment that the Beacon 410A could have made to the response reading with the calibration gas that was used for each direct connect type channel during the most recent successful calibration. So if a 0 - 100% LEL channel is calibrated using 50% LEL gas and the maximum indicated span in the VIEW MAX SPANS screen is 95% LEL, this means that there was enough adjustment left on that channel to set the reading to 95% LEL when the detector was exposed to 50% LEL gas. If the maximum span value is close to the calibration gas value, for example if it is 53% LEL for a 0 - 100% LEL channel when 50% LEL calibration gas is used, the sensor should be replaced soon.

To make the maximum span values as meaningful as possible, there is a limit to how much remaining adjustment the screen will indicate. The maximum remaining adjustment that will be shown for any channel is 3 times the calibration gas concentration even if the Beacon 410A could have adjusted it higher. For example, if 50% LEL gas was used to calibrate a 0 - 100% LEL channel, the highest maximum span value that will be displayed is 150% LEL. If the maximum span adjustment possible for a channel is more than 3 times the calibration gas value, a “+” sign will be displayed next to the maximum span value.

The maximum span values that are displayed are from the most recent successful calibration for each channel. So they are most useful soon after a calibration is performed. If an extended period of time, for example 2 or 3 months, has passed since the last successful calibration on a particular channel, the maximum span value for that channel may no longer be accurate.

The maximum span value only has meaning for direct connect type channels. For 4 - 20 mA transmitter type channels, instead of a maximum span value, **4 - 20 mA Xmtr** will be displayed for those channels.

To view the maximum span values, do the following:

1. Navigate to the Select Operation Screen as described in “Entering Calibration Mode” on page 63 or navigate to the Select Operation Screen after performing a calibration.
2. Use the UP/YES or DOWN/NO button to display **VIEW MAX SPANS** on the Select Operation Screen.
3. Press and hold the ENTER button to display the maximum spans. In the example below, channels 1, 2, and 3 are active and channel 2 is a 4 - 20 mA type channel.

1	:	M E T H A N E	1 5 0 + % L E L
2	:	4 - 2 0 m A	X m t r
3	:	O X Y G E N	3 7 . 5 % : V O L

4. Release the ENTER button to return to the Select Operation screen.
5. Press and release the ESCAPE button to return to the initial Calibration Mode Screen that says **You Have Entered the CALIBRATION Menu...** and then press and release the DOWN/NO button to exit Calibration Mode and return to normal operation.

# Chapter 9: RS-485 Modbus Output

---

## Overview

This chapter describes the Beacon 410A's RS-485 Modbus output and how to configure the Beacon 410A to make use of it. It also discusses how to wire the Beacon 410A into a Modbus system.

The Beacon 410A provides an RS-485 serial communications interface. It is a Modbus Slave Device, supporting 2-wire RS-485 Modbus RTU serial communications.

---

## Wiring the Beacon 410A in a Modbus System

The Beacon 410A is a 2-wire Modbus RTU device. When wiring the Beacon 410A into a Modbus system, adhere to standard Modbus wiring practices per the Modbus Over Serial Line Specification and Implementation Guide V1.0 or later. This document can be found online at [www.modbus.org/specs.php](http://www.modbus.org/specs.php).

The Modbus protocol supports a maximum of 247 unique slave addresses (1-247). The Beacon 410A's line driver provides for up to 32 Beacon 410As (or some combination of Beacon 410As and other Modbus slave devices such as the RKI Instruments M2) to be connected together without the need for a repeater. Figure 19 & Figure 20 below illustrate typical Beacon 410A wiring configurations. If more than 32 Beacon 410As (or Beacon 410As and other slave devices) need to be connected together, an RS-485 repeater(s) should be used such that no more than 32 Beacon 410As reside on any given network segment.

The MODBUS terminals are located on the controller terminal strip (See Figure 2). The following signals are available at the Modbus terminals:

**Table 11: Modbus Terminal Signals**

<b>Modbus Terminal Label (RS-485 Name)</b>	<b>Modbus Signal Name</b>
A	D0
B	D1
C	Common

### ***Ground Jumper***

The Beacon 410A includes a 2-pin ground header (see Figure 2 on page 10) with a jumper that is used when the Beacon 410A is in a Modbus system. If the Beacon 410A is not wired into a Modbus system, the jumper should be installed. If it is wired into a Modbus system, it should be removed.

# Recommended Modbus Wiring

The recommended Modbus wiring for the Beacon 410A is illustrated in Figure 18 below.

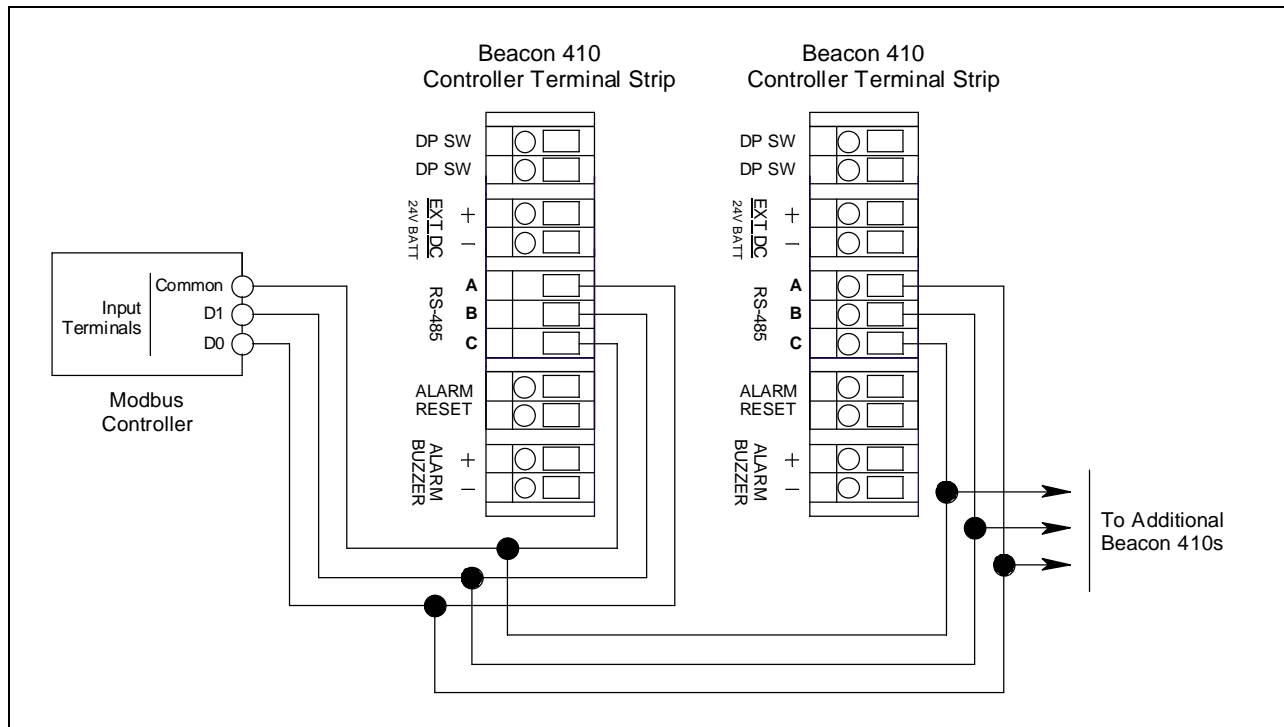

Figure 18: Recommended Modbus Wiring

## Adding a Beacon 410A to an Existing Beacon 410 Installation with Older Beacon 410s

A Beacon 410A may be wired into an existing Beacon 410 Modbus system where the Beacon 410s do not have a ground header and jumper. The wiring connections are identical and the ground jumper on the Beacon 410A must remain installed.

## **Termination Jumper**

The Beacon 410A includes a 2-pin termination header (see Figure 2) that may need to be installed when the Beacon 410A is used in a Modbus system. Every Beacon 410A is supplied with a termination jumper (a jumper block) installed onto this header. If the Beacon 410A is not used in a Modbus system, this jumper has no function. When the Beacon 410A is installed in a Modbus system, this jumper must be installed in a Beacon 410A that is at the end of a Modbus line. Any Beacon 410A in a Modbus system that is not at the end of a line must have the termination jumper removed (see Figure 19 & Figure 20).



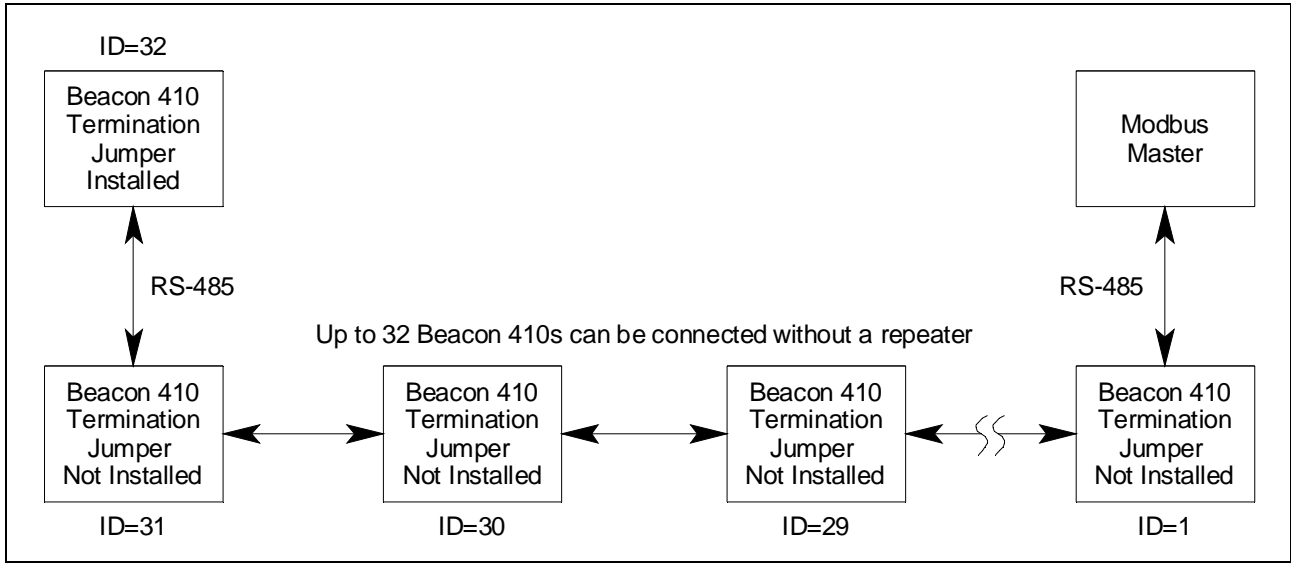

**Figure 19: Multiple Beacon 410As in a Daisy Chain Configuration**

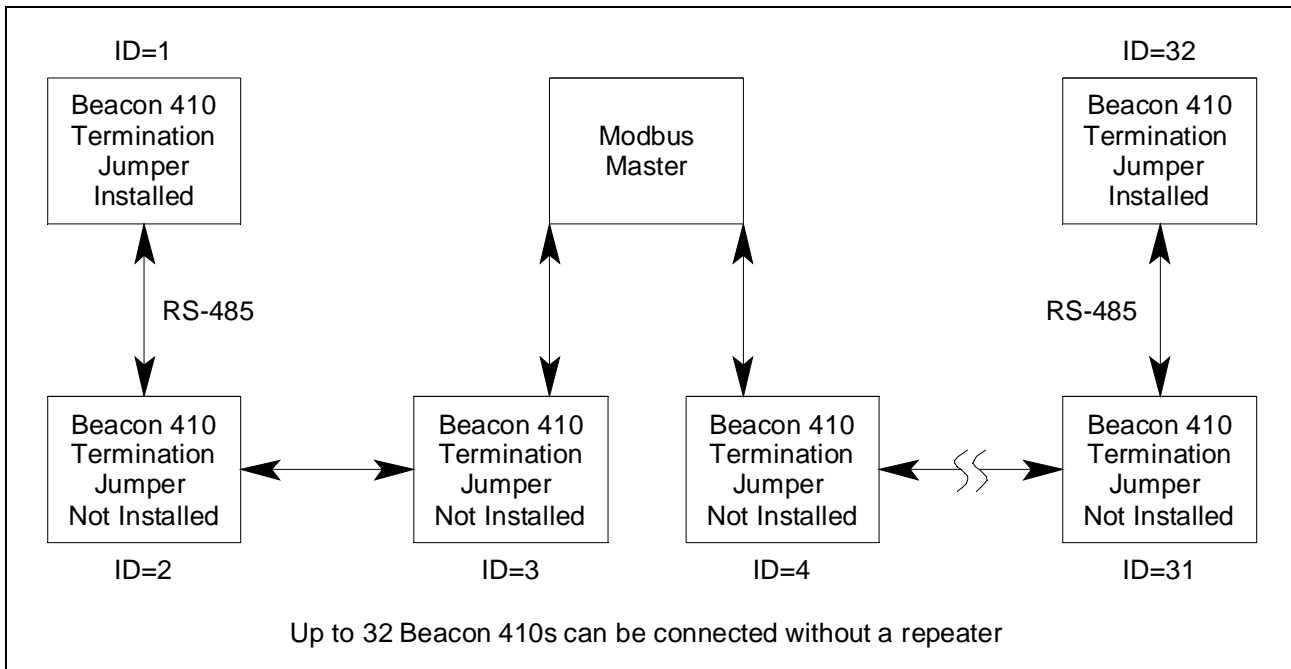

**Figure 20: Multiple Beacon 410As in a Two Branch Configuration**

---

# Using the Beacon 410A in a 4-wire Modbus System

Although the Beacon 410A is a 2-wire Modbus RTU device, it can be used with a 4-wire Modbus controller if the system wiring is modified as follows:

- Connect the controller's TxD0 and RxD0 wires together and use this connection as the 2-wire Modbus D0 signal.
- Connect the controller's TxD1 and RxD1 wires together and use this connection as the 2-wire Modbus D1 signal.
- Connect these D0 and D1 signals and the common wire from the controller to the 2-wire Modbus Network of Beacon 410As.

---

## Modbus Menu

The Modbus Menu allows you to configure various parameters relating to the Modbus setup of the Beacon 410A. The Modbus Menu includes a 5-minute timeout feature. If you do not press a control button for 5 minutes, the Beacon 410A automatically returns to normal operation.

---

**NOTE:** If the Beacon 410A returns to normal operation because of a timeout, it enters a warm-up period just as it does when it is first turned on.

---

1. While in normal operation, simultaneously press and hold the ENTER and DOWN/NO buttons for approximately 5 seconds to enter the Modbus Menu. Release the buttons when the **You Have Entered the MODBUS Menu** message appears on the display.
2. Press and release the UP/YES button to continue in the Modbus Menu to the Modbus Feature Enable/Disable screen.

```
MODBUS Feature is :
                D I S A B L E D
UP / DN then ENT / ESC
```

3. In the parameter screens, use the ENTER button to accept a displayed parameter setting and proceed to the next parameter or the ESCAPE button to backup a screen.
4. If you want to change a displayed parameter setting, use the UP/YES or DOWN/NO button to change the parameter to the desired setting, then press and release the ENTER button to accept the change and proceed to the next screen.
5. Continue through the parameter setting screens changing any parameter settings as needed until the following message appears on the display.

```
Save Settings ?
[ Y / N ]
[ E S C A P E ]   t o   b a c k   u p
```

6. To save the channel parameter settings, press and release the UP /YES button. The screen will indicate that the Beacon 410A is saving the settings for a few seconds then the Beacon 410A will return to normal operation.

If you do not want to save the channel parameter settings, press and release the DOWN/NO button. The display will indicate that no settings have been changed for a few seconds then the Beacon 410A will return to normal operation.

Table 12 lists the Modbus configuration parameters that can be configured in the Modbus Menu along with the factory set value for each parameter.

**Table 12: Modbus Configuration Parameters**

<b>Modbus Mode Parameter</b>	<b>Available Settings &amp; Description</b>
Enabled/Disabled	Can be set to ENABLED or DISABLED (factory setting). Enables or disables the Modbus output.
Slave ID	The Slave ID can be set to values from 1 (factory setting) to 247.  The Beacon 410A will only receive messages from the Master which are addressed to this Slave ID (except for broadcast messages which are received by all slaves)
Baud Rate	Can be set to 1200, 2400, 4800, 9600 (factory setting), 14440, 19200, & 38400
Parity	EVEN (factory setting), ODD, NONE
Response Delay	The response delay can be set from 0 (factory setting) to 20 mS.  This is an optional additional delay inserted by the Beacon 410A prior to returning a response message to the Master. It may be helpful in some installations where the Master's preparedness to receive responses might be delayed.

---

**NOTE:** All Beacon 410As on a Modbus network must be configured with the same baud rate and parity, and each Beacon 410A must have a unique slave ID. For a Beacon 410A to participate on a network, the ENABLED/DISABLED setting must be set to ENABLED.

---

---

# Supported Modbus Functions

The Beacon 410A supports Function Code 03, Read Holding Registers. There are a total of 41 registers available to be read via this Function Code but they are not sequential registers. Five separate register sets must be queried in order to read all of the available registers.

## ***Register 40001, Instrument Information***

The format for the first register, register 40001, is shown below in Table 13. Register 40001 gives information about the instrument as a whole, and should be checked before reading or interpreting the channel data in the registers that follow. When the Beacon 410A is in any operating menu or mode other than normal operation, the channel registers simply hold their existing values. Once the Beacon 410A returns to normal operation, the channel registers are updated each second.

**Table 13: Register 40001**

<b>Current Operating Mode (MS-Byte)</b>	<b>Common Resource Status Bits “1” = Energized “0” = De-Energized (LS-Byte)</b>
<ul style="list-style-type: none"><li>• 0 = Normal Operation</li><li>• 1 = Factory (Reserved)</li><li>• 2 = Input Setup Menu</li><li>• 3 = Channel Configuration Menu</li><li>• 4 = Global Menu</li><li>• 5 = Modbus Menu</li><li>• 6 = Calibration Mode</li><li>• 7 = Min/Max Display</li><li>• 8 = Low Power Standby</li></ul>	<ul style="list-style-type: none"><li>• Bit-7 (msb) = Common Fail Relay</li><li>• Bit-6 = Relay-A</li><li>• Bit-5 = Relay-B</li><li>• Bit-4 = Relay-C</li><li>• Bit-3 = Relay-D</li><li>• Bit-2 = Strobe (optional)</li><li>• Bit-1 = Audible Alarm (Buzzer)</li><li>• Bit-0 (lsb) = (this bit is not used)</li></ul>

# **Registers 40002 and 40007 - 40015, Channel 1 Information**

## **Register 40002**

Table 14 below shows the information in register 40002.

**Table 14: Register 40002**

<b>Channel Operational State (MS-Byte)</b>	<b>Channel Status Bits (LS-Byte)</b>
<ul style="list-style-type: none"><li>• 0 = (this code is not used)</li><li>• 1 = Standby</li><li>• 2 = Normal Operation</li><li>• 3 = Warm Up</li><li>• 4 = Fail</li><li>• 5 = Post-Calibration</li><li>• 6 = Low Power</li></ul>	<ul style="list-style-type: none"><li>• Bit-7 (msb) = Relay-1 (1 = energized)</li><li>• Bit-6 = Relay-2 (1 = energized)</li><li>• Bit-5 = (this bit is not used)</li><li>• Bit-4 = Alarm-1 (1 = asserted)</li><li>• Bit-3 = Alarm-2 (1 = asserted)</li><li>• Bit-2 = Alarm-3 (1 = asserted)</li><li>• Bits[1:0] = Channel Usage Code<ul style="list-style-type: none"><li>• [00] = Not Used</li><li>• [01] = Standby</li><li>• [10] = Active</li><li>• [11] = unused code</li></ul></li></ul>

## **Registers 40007 - 40010**

The 8 bytes (characters) in these registers contain the channel gas name in ASCII characters.

## **Registers 40011 - 40013**

The 6 bytes (characters) in these registers contain the channel gas reading in ASCII characters.

## **Registers 40014 - 40015**

The 4 bytes (characters) in registers 40014 and 40015 contain the channel gas units in ASCII characters.

## **Registers 40016 and 40021 - 40029, Channel 2 Information**

### **Register 40016**

Table 15 below shows the information in register 40016.

**Table 15: Register 40016**

<b>Channel Operational State (MS-Byte)</b>	<b>Channel Status Bits (LS-Byte)</b>
<ul style="list-style-type: none"><li>• 0 = (this code is not used)</li><li>• 1 = Standby</li><li>• 2 = Normal Operation</li><li>• 3 = Warm Up</li><li>• 4 = Fail</li><li>• 5 = Post-Calibration</li><li>• 6 = Low Power</li></ul>	<ul style="list-style-type: none"><li>• Bit-7 (msb) = Relay-1 (1 = energized)</li><li>• Bit-6 = Relay-2 (1 = energized)</li><li>• Bit-5 = (this bit is not used)</li><li>• Bit-4 = Alarm-1 (1 = asserted)</li><li>• Bit-3 = Alarm-2 (1 = asserted)</li><li>• Bit-2 = Alarm-3 (1 = asserted)</li><li>• Bits[1:0] = Channel Usage Code<ul style="list-style-type: none"><li>• [00] = Not Used</li><li>• [01] = Standby</li><li>• [10] = Active</li><li>• [11] = unused code</li></ul></li></ul>

### **Registers 40021 - 40024**

The 8 bytes (characters) in these registers contain the channel gas name in ASCII characters.

### **Registers 40025 - 40027**

The 6 bytes (characters) in these registers contain the channel gas reading in ASCII characters.

### **Registers 40028 - 40029**

The 4 bytes (characters) in registers 40028 and 40029 represent the channel gas units in ASCII characters.

## ***Registers 40030 and 40035 - 40043, Channel 3 Information***

### **Register 40030**

Table 16 below shows the information in register 40030.

**Table 16: Register 40030**

<b>Channel Operational State (MS-Byte)</b>	<b>Channel Status Bits (LS-Byte)</b>
<ul style="list-style-type: none"><li>• 0 = (this code is not used)</li><li>• 1 = Standby</li><li>• 2 = Normal Operation</li><li>• 3 = Warm Up</li><li>• 4 = Fail</li><li>• 5 = Post-Calibration</li><li>• 6 = Low Power</li></ul>	<ul style="list-style-type: none"><li>• Bit-7 (msb) = Relay-1 (1 = energized)</li><li>• Bit-6 = Relay-2 (1 = energized)</li><li>• Bit-5 = (this bit is not used)</li><li>• Bit-4 = Alarm-1 (1 = asserted)</li><li>• Bit-3 = Alarm-2 (1 = asserted)</li><li>• Bit-2 = Alarm-3 (1 = asserted)</li><li>• Bits[1:0] = Channel Usage Code<ul style="list-style-type: none"><li>• [00] = Not Used</li><li>• [01] = Standby</li><li>• [10] = Active</li><li>• [11] = unused code</li></ul></li></ul>

### **Registers 40035 - 40038**

The 8 bytes (characters) in these registers contain the channel gas name in ASCII characters.

### **Registers 40039 - 40041**

The 6 bytes (characters) in these registers contain the channel gas reading in ASCII characters.

### **Registers 40042 - 40043**

The 4 bytes (characters) in registers 40042 and 40043 contain the channel gas units in ASCII characters.

## **Registers 40044 and 40049 - 40057, Channel 4 Information**

### **Register 40044**

Table 17 below shows the information in register 40044.

**Table 17: Register 40044**

<b>Channel Operational State (MS-Byte)</b>	<b>Channel Status Bits (LS-Byte)</b>
<ul style="list-style-type: none"><li>• 0 = (this code is not used)</li><li>• 1 = Standby</li><li>• 2 = Normal Operation</li><li>• 3 = Warm Up</li><li>• 4 = Fail</li><li>• 5 = Post-Calibration</li><li>• 6 = Low Power</li></ul>	<ul style="list-style-type: none"><li>• Bit-7 (msb) = Relay-1 (1 = energized)</li><li>• Bit-6 = Relay-2 (1 = energized)</li><li>• Bit-5 = (this bit is not used)</li><li>• Bit-4 = Alarm-1 (1 = asserted)</li><li>• Bit-3 = Alarm-2 (1 = asserted)</li><li>• Bit-2 = Alarm-3 (1 = asserted)</li><li>• Bits[1:0] = Channel Usage Code<ul style="list-style-type: none"><li>• [00] = Not Used</li><li>• [01] = Standby</li><li>• [10] = Active</li><li>• [11] = unused code</li></ul></li></ul>

### **Registers 40049 - 40052**

The 8 bytes (characters) in these registers contain the channel gas name in ASCII characters.

### **Registers 40053 - 40055**

The 6 bytes (characters) in these registers contain the channel gas reading in ASCII characters.

### **Registers 40056 - 40057**

The 4 bytes (characters) in registers 40056 and 40057 contain the channel gas units in ASCII characters.



# Chapter 10: Maintenance

---

**WARNING:** *Only authorized and properly trained personnel should perform any maintenance procedures.*

---

---

## Overview

This chapter describes preventive maintenance procedures for the Beacon 410A and how to replace the AC fuses. It includes a troubleshooting guide for problems you may encounter with the Beacon 410A.

---

## Preventive Maintenance

Preventive maintenance of the Beacon 410A consists of daily, monthly, and quarterly procedures to ensure that the installed detector heads remain on zero (20.9 for oxygen) in fresh air and are responsive to the target gas. See the detector head operator's manuals for preventive maintenance procedures for each installed detector head.

---

## Troubleshooting

Table 18 describes symptoms, probable causes, and recommended actions for the most common problems you may encounter with the Beacon 410A.

---

**NOTE:** This troubleshooting guide describes **Beacon 410A** problems only. See the detector head operator's manuals for preventive maintenance procedures that apply to the detector heads installed on your Beacon 410A.

---

**Table 18: Troubleshooting the Beacon 410A**

Condition	Symptom(s)	Probable Causes	Recommended Action
No Power to Instrument and/or Display PCB	<ul style="list-style-type: none"><li>The PILOT light is off.</li><li>The display screen is blank.</li></ul>	<ul style="list-style-type: none"><li>The power wiring is disconnected or misconnected.</li><li>The AC fuse is blown.</li><li>The display cable is disconnected or misconnected.</li></ul>	<ol style="list-style-type: none"><li>Verify that the wiring to the power source is correct and secure.</li><li>At the Beacon 410A, verify that the wiring to the AC in terminal strip is correct and secure.</li><li>Check the continuity of the AC fuses.</li><li>Verify that the display cable is connected. The display (ribbon) cable plugs into a rectangular connector on the top edge of the control PCB and on the top edge of the main PCB (labeled <b>Front Panel</b>).</li><li>If the power difficulties continue, contact RKI for further instruction.</li></ol>

**Table 18: Troubleshooting the Beacon 410A (Continued)**

Condition	Symptom(s)	Probable Causes	Recommended Action
Frequent or Suspect Alarms	<ul style="list-style-type: none"> <li>• The Beacon 410A alerts you to frequent or suspect alarms.</li> <li>• The detector heads' fresh air readings remain on zero (20.9 for oxygen) despite alarm occurrences.</li> </ul>	<ul style="list-style-type: none"> <li>• The Beacon 410A is experiencing false readings due to RFI or EMI.</li> <li>• The detector head wiring has one or more intermittent connections.</li> </ul>	<ol style="list-style-type: none"> <li>1. Verify that the detector head wiring is properly shielded.</li> <li>2. Verify that the detector head wiring is correct and secure.</li> <li>3. Verify that power and detector head wiring is routed through separate conduit hubs on the bottom of the Beacon 410A housing.</li> <li>4. Increase the alarm on delay setting in the Configuration Menu.</li> <li>5. Increase the noise filter in the Configuration Menu.</li> <li>6. If the frequent or suspect alarm difficulties continue, contact RKI for further instruction.</li> </ol>
Momentarily Unstable Gas Readings on Display	<ul style="list-style-type: none"> <li>• The display reading for one or more channels rises or falls briefly and then returns to the normal fresh air reading.</li> </ul>	<ul style="list-style-type: none"> <li>• The Beacon 410A is experiencing false readings due to RFI or EMI.</li> <li>• The detector head wiring has one or more intermittent connections.</li> <li>• The noise filter setting is too low.</li> <li>• The dead band setting is too low.</li> <li>• The display screen is malfunctioning.</li> </ul>	<ol style="list-style-type: none"> <li>1. Verify that the detector head wiring is properly shielded.</li> <li>2. Verify that the detector head wiring is correct and secure.</li> <li>3. Verify that power and detector head wiring is routed through separate conduit hubs on the bottom of the Beacon 410A housing.</li> <li>4. Increase the noise filter setting in the Configuration Menu.</li> <li>5. Increase the dead band setting in the Configuration Menu.</li> <li>6. If the difficulties continue, contact RKI for further instruction.</li> </ol>
Buzzer not Working	<ul style="list-style-type: none"> <li>• The buzzer does not sound an audible alarm during alarm conditions.</li> <li>• The buzzer sounds weak or broken.</li> </ul>	<ul style="list-style-type: none"> <li>• The buzzer is disconnected or misconnected.</li> <li>• The buzzer is malfunctioning.</li> </ul>	<ol style="list-style-type: none"> <li>1. Verify that the wiring to the <b>ALARM BUZZER</b> - and <b>ALARM BUZZER +</b> terminals of the controller terminal strip is correct and secure.</li> <li>2. If the buzzer difficulties continue, contact RKI for further instruction.</li> </ol>
Reset Switch not Working	<ul style="list-style-type: none"> <li>• Depending on the instrument setup, the buzzer or strobe does not turn off in the appropriate situation when the reset switch is pressed.</li> <li>• The applicable alarm circuit does not reset when you press the reset switch after an alarm condition passes.</li> </ul>	<ul style="list-style-type: none"> <li>• The reset switch is disconnected or misconnected.</li> <li>• The reset switch is malfunctioning.</li> <li>• The Beacon 410A is not properly setup for the desired reset switch operation.</li> </ul>	<ol style="list-style-type: none"> <li>1. Verify that the wiring to the <b>ALARM RESET</b> (2) terminals of the controller terminal strip is correct and secure.</li> <li>2. If the reset switch difficulties continue, contact RKI for further instruction.</li> <li>3. Make sure that the Beacon 410A is properly setup in the Global Menu and Configuration Menus for the desired reset switch operation.</li> </ol>

---

# Replacing the Fuses

The Beacon 410A has two user serviceable AC fuses and one user serviceable DC fuse. The replacement AC fuses must be rated to 6 A, 250 V, 1/4 x 1 1/4 inch, fast acting. The replacement DC fuse must be rated to 10A, 250V, 1/4 x 1 1/4 inch, fast acting.

---

**NOTE:** To replace other components of the Beacon 410A, contact RKI Instruments, Inc., for further information.

---

1. Turn off or unplug all incoming power to the Beacon 410A.
2. Open the Beacon 410A housing door, then place the power switch in the OFF position.
3. The fuses are located to the left of the AC in terminal strip. Use a flat-blade screwdriver to rotate the applicable fuse holder 1/4 turn counterclockwise. The fuse holder releases from the socket.
4. Remove the fuse holder from the socket, then remove the fuse from the fuse holder.

---

**CAUTION:** *Verify that the replacement fuses are the same type and rating as the fuses you are replacing. The Beacon 410A's AC fuses are fast blow fuses rated for 6A, 250 V and the DC fuse is a fast blow fuse rated for 10A, 250V.*

---

5. Install the replacement fuse in the fuse holder, then place the fuse holder in the socket.
6. Push the fuse holder into the socket, then turn the holder 1/4 turn clockwise to secure it in the socket.
7. Plug in or turn on all incoming power to the Beacon 410A.
8. Place the Beacon 410A's power switch in the ON position, then verify that the PILOT light is on.
9. Close and secure the housing door.

# Chapter 11: Parts List

Table 19 lists the part numbers and descriptions for replacement parts and accessories offered for the Beacon 410A Gas Monitor.

**Table 19: Parts List, Beacon 410A Gas Monitor**

<b>Part No.</b>	<b>Description</b>
18-0107RK	Conduit hub (3/4 in.)
43-0440RK	Reset switch
43-4170RK	AC fuse, 6A, 250 V, 1/4 x 1 1/4 inch, fast acting
43-4179RK	DC fuse, 10A, 250V, 1/4 x 1/4 inch, fast acting
51-0096RK	Strobe/horn, 10 - 33 VDC, NEMA 4X
51-0170	Strobe, amber, 12 - 48 VDC, NEMA 4X
51-0171	Strobe, blue, 12 - 48 VDC, NEMA 4X
51-0174	Strobe, red, 12 - 48 VDC, NEMA 4X
52-1016RK	Buzzer
71-0397	Beacon 410A Gas Monitor Operator's Manual (this document)